



## ST Multistage Submersible Pumps

---

Made in Taiwan



Catalogo 50 Hz



## SISTEMA 4" ST Submersible Pumps

**Discharge Head and Motor Adaptor** are precision machined cast 304 stainless steel for superior strength and durability. The motor adaptor is NEMA standard.

**Impellers** are floating type made with Noryl® for a superior sand handling. Together with glass filled polycarbonate diffusers make the super strong pumps for maximum wear and abrasive resistance. The materials are FDA compliant materials.

**Impeller Bowls** are made from 304 stainless steel, maximizing wear from abrasion.

**Shaft Coupling** is made from 304 stainless steel for easy alignment to the motor shaft.

**Strainer** is made from stamped 304 stainless steel for rigidity.

**Non-Return valve** made from 304 stainless steel, fitted in the discharge to prevent any back flow of water and alleviate any water hammer to the pumps.

**Pump Shaft** is made from hex 304 stainless steel bar material for high corrosion resistance.

**Bearing** is made with Polyacetal for strong wear and abrasive resistance.

**Pump body** is covered by a 1.5mm thick 304 polished stainless steel casing, ensures optimum resistance to abrasion.

### APPLICATIONS

- Water Supply
- Irrigation
- Pressure Boosting

### GENERAL SPECIFICATIONS PUMP

- Delivery: up to 24 m<sup>3</sup> /h at 2850 rpm
- Head: up to 322 m at 2850 rpm
- Maximum permissible quantity of sand: 50g/m<sup>3</sup>
- ST05-ST07-ST10-ST13-ST18 models Rp1 ¼" discharge.
- ST25 model 1 ½" discharge.
- ST35-ST40-ST55-ST60-ST80 models Rp 2" discharge.
- Motor Power: from 0.37 to 7.5 kW.

### MOTOR

Flange	4" NEMA standard
Degree of protection	IP 68
Insulation class	F
Single phase motors	0.37 kW up to 4 kW
Three phase motors	0.37 kW up to 7.5 kW
Standard voltages	1~ 220V-230V 3~ 230Vor 400V
Cable length	1.7 M 0.37 kW up to 1.5 kW 2.5 M 2.2 kW up to 7.5 kW

**Performance Range**

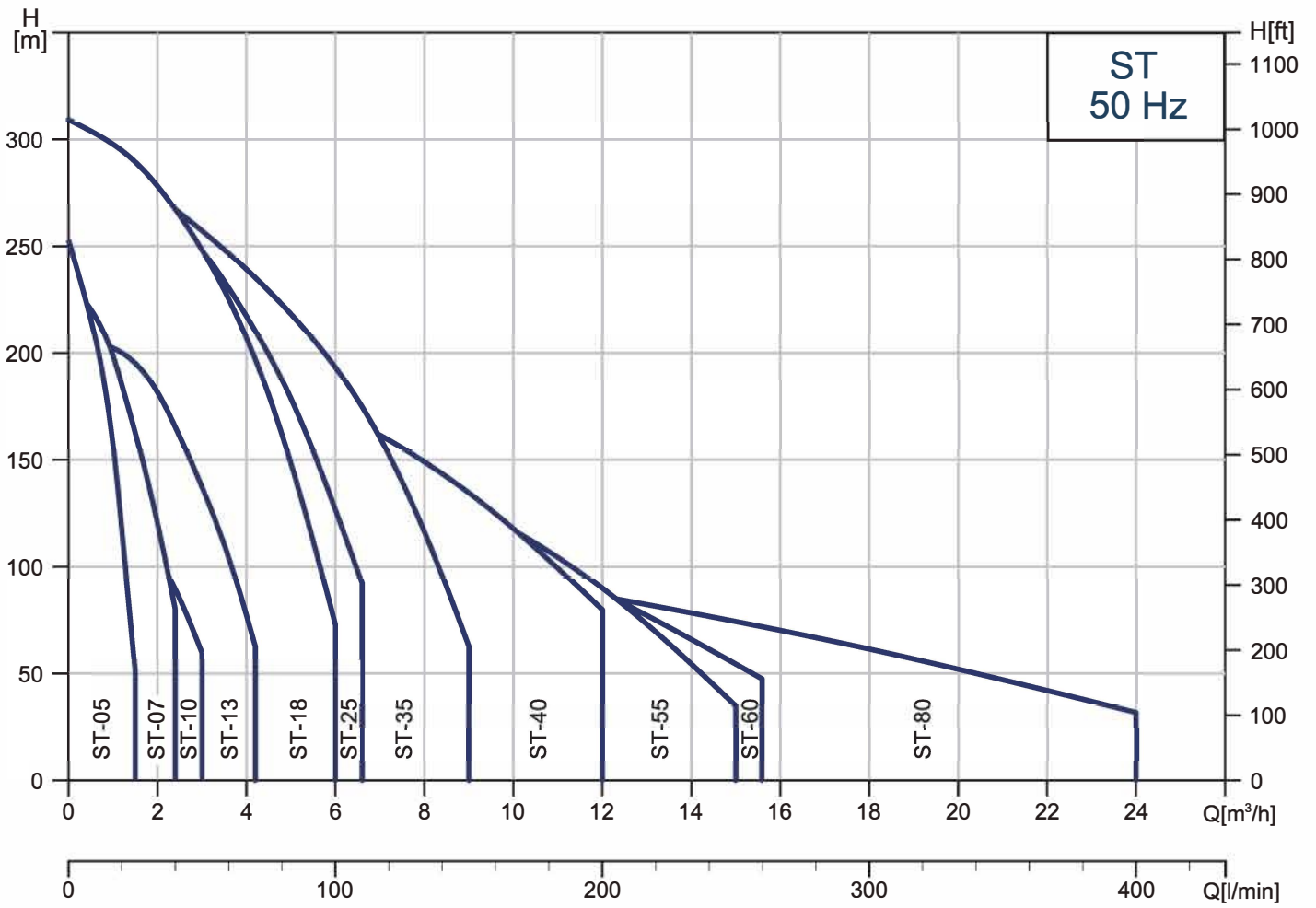

## Material Specification

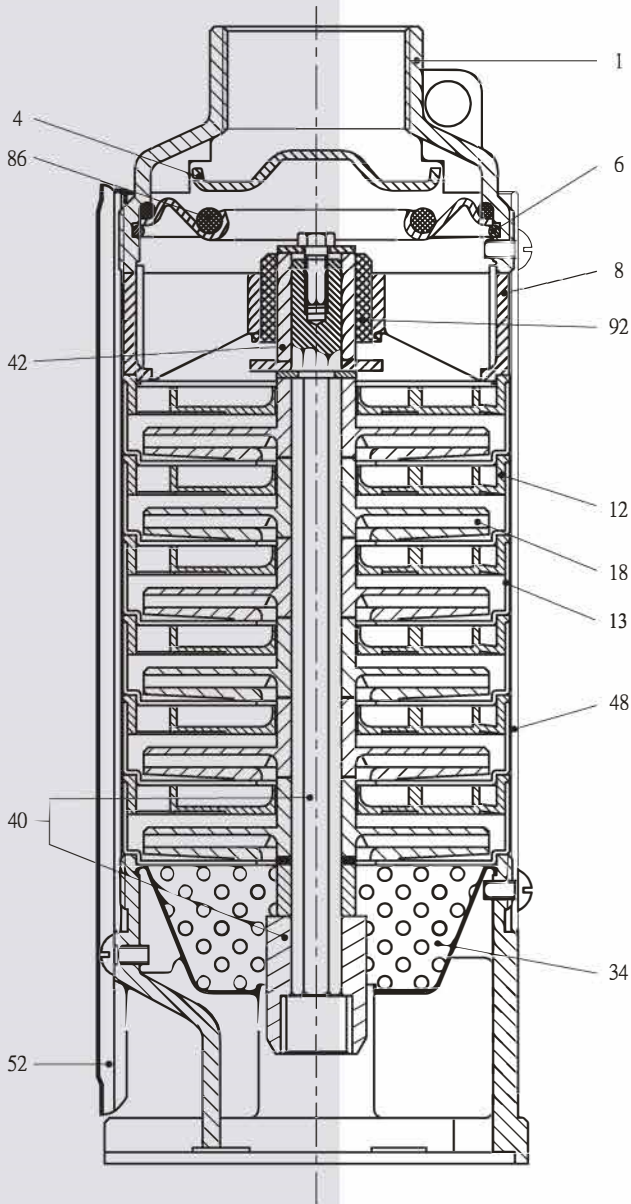

Pos.	Part Name	Material
01	Discharge Head	AISI 304 SS
04	Check Valve Cone	AISI 304 SS
06	Check Valve retaining Ring	AISI 304 SS
08	Bearing Spider	Glass Filled Polycarbonate
12	Diffuser	Glass Filled Polycarbonate
13	Bowl	AISI 304 SS
18	Impeller	Noryl
34	Strainer	AISI 304 SS
40	Pump Shaft/ Coupling	AISI 304 SS
42	Shaft Sleeve	AISI 304 SS or Noryl
48	Pump Casing	AISI 304 SS
52	Cable Guard	AISI 304 SS
86	O-Ring	NBR
92	Bearing	Polyacetal

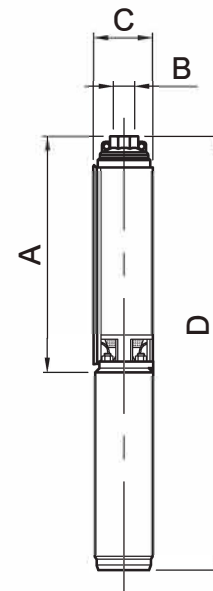
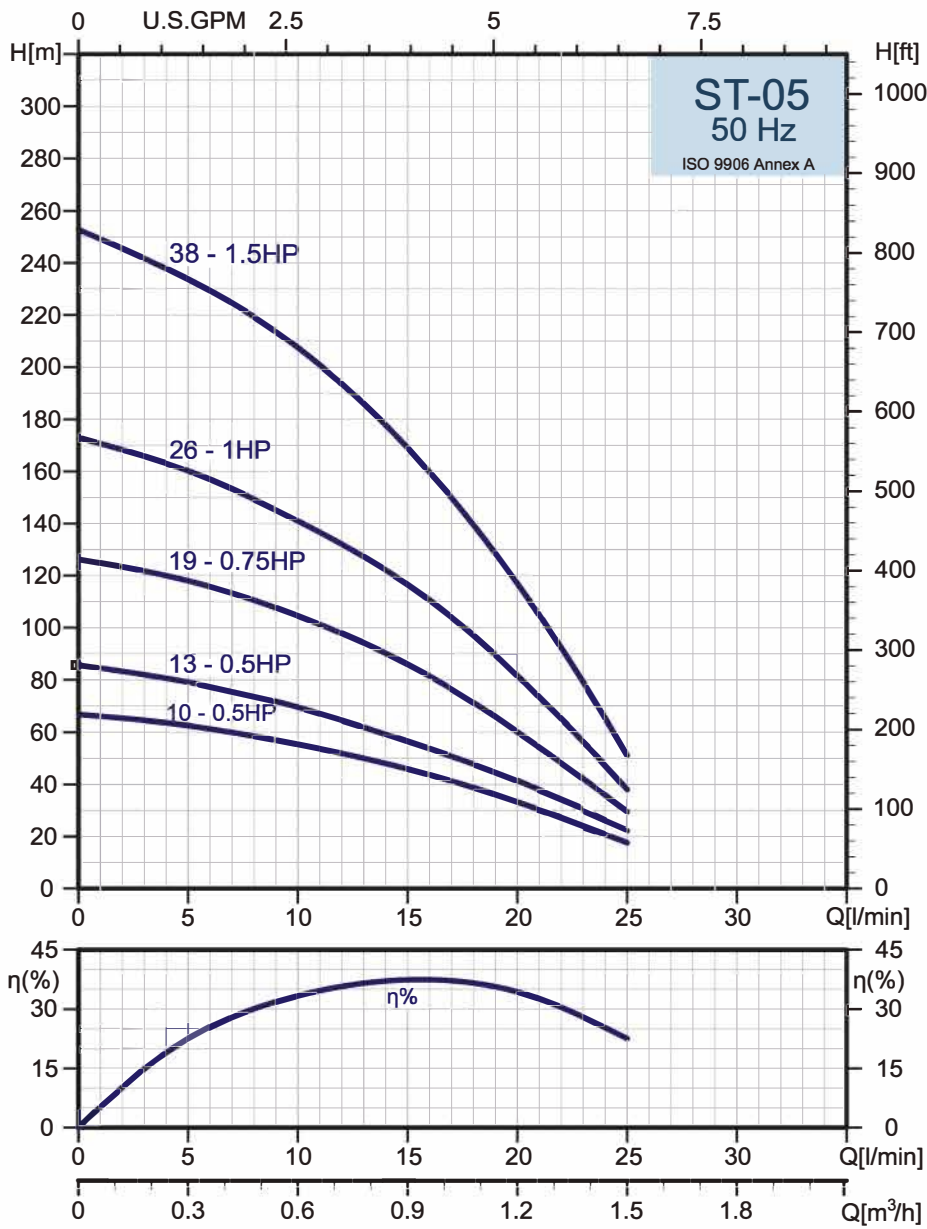

Single Phase Motor				
Dimensions and Weights				
Pump Type	Dimensions(mm)			
	A	B	C	D
ST-0510	324	RP/ NPT 1 1/4"	98	670
ST-0513	377		98	723
ST-0519	481		98	846
ST-0526	642		98	1022
ST-0538	864		98	1307

Three Phase Motor				
Dimensions and Weights				
Pump Type	Dimensions(mm)			
	A	B	C	D
ST-0510	324	RP/ NPT 1 1/4"	98	654
ST-0513	377		98	707
ST-0519	481		98	827
ST-0526	642		98	1007
ST-0538	864		98	1282

## Selection Chart

PUMP TYPE	STAGES	MOTOR		Q=DELIVERY									
				l/min	0	5	10	15	20	25	30	PUMP	ELECTRO PUMP
		KW	HP	m³/h	0	0.3	0.6	0.9	1.2	1.5	1.8	Net Weight(kg)	
		H=TOTAL HEAD IN METERS										Single phase	Three phase
ST-0510	10	0.37	0.5	67	63	55	46	33	18		3.3	10.6	10.0
ST-0513	13	0.37	0.5	86	78	70	56	42	23		3.7	11.0	10.4
ST-0519	19	0.55	0.75	126	118	105	86	60	30		4.7	12.9	12.1
ST-0526	26	0.75	1	173	160	141	117	81	39		5.8	14.6	14.0
ST-0538	38	1.1	1.5	253	234	208	169	117	52		9.2	19.2	18.1

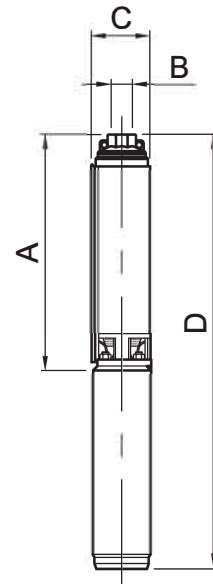
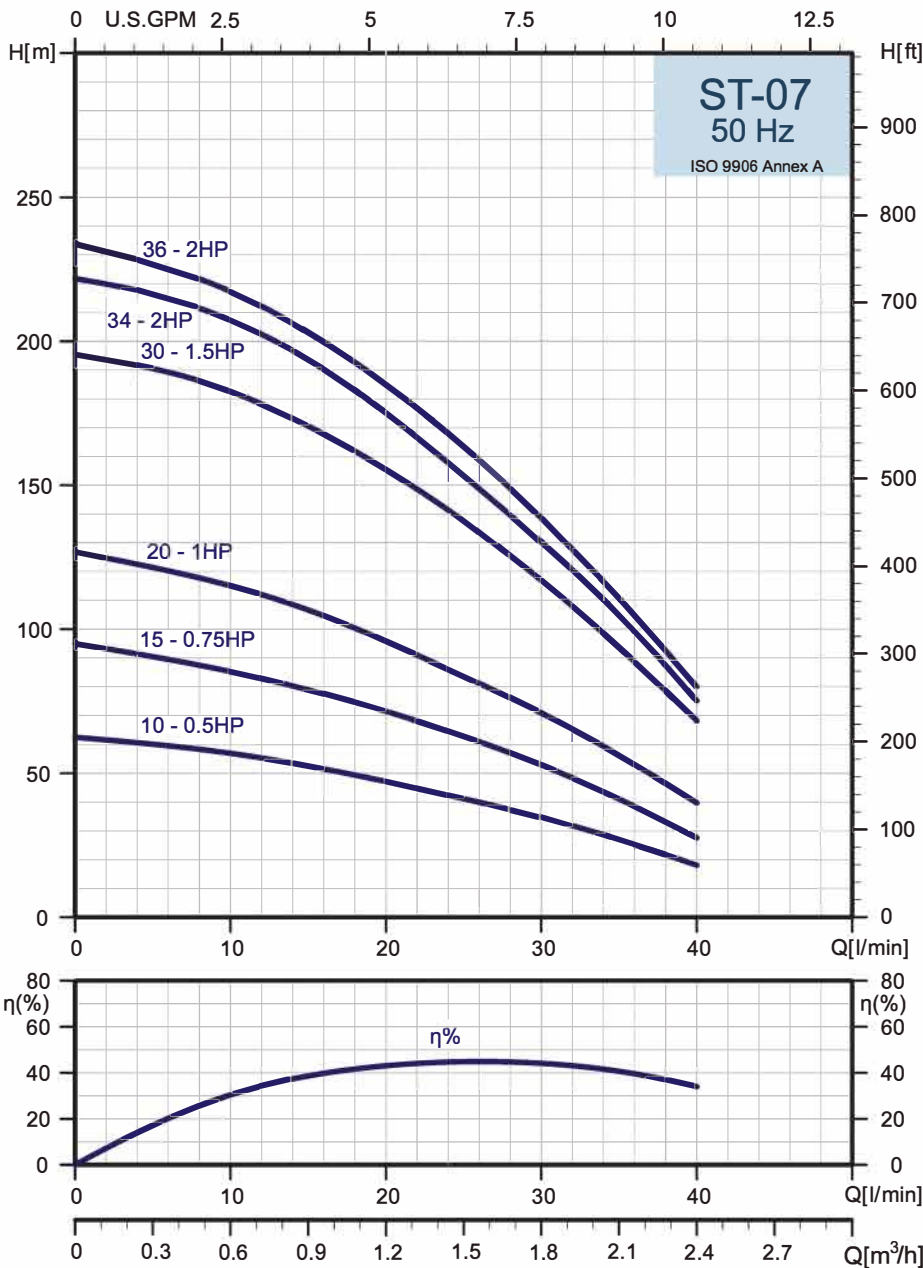

Single Phase Motor				
Dimensions and Weights				
Pump Type	Dimensions(mm)			
	A	B	C	D
ST-0710	330	RP/ NPT 1 1/4"	98	676
ST-0715	420		98	785
ST-0720	510		98	890
ST-0730	730		98	1135
ST-0734	833		98	1273
ST-0736	868		98	1308

Three Phase Motor				
Dimensions and Weights				
Pump Type	Dimensions(mm)			
	A	B	C	D
ST-0710	330	RP/ NPT 1 1/4"	98	660
ST-0715	420		98	766
ST-0720	510		98	875
ST-0730	730		98	1110
ST-0734	833		98	1238
ST-0736	868		98	1273

## Selection Chart

PUMP TYPE	STAGES	MOTOR		Q=DELIVERY												PUMP	ELECTRO PUMP	
				H=TOTAL HEAD IN METERS													Net Weight(kg)	
		KW	HP	l/min 0	5	10	15	20	25	30	35	40	45	Single phase	Three phase			
				m³/h 0	0.3	0.6	0.9	1.2	1.5	1.8	2.1	2.4	2.7					
ST-0710	10	0.37	0.5	63		57	53	47	42	35	27	18		3.3	10.6	10.0		
ST-0715	15	0.55	0.75	95		86	78	72	63	53	41	28		4.3	12.5	11.7		
ST-0720	20	0.75	1.0	127		115	107	96	84	71	56	40		5.3	14.1	13.5		
ST-0730	30	1.1	1.5	195		183	171	156	138	117	94	69		7.4	17.4	16.3		
ST-0734	34	1.5	2.0	222		207	194	175	154	130	104	76		9.3	20.8	19.3		
ST-0736	36	1.5	2.0	234		217	203	185	164	138	110	80		9.8	21.3	19.8		

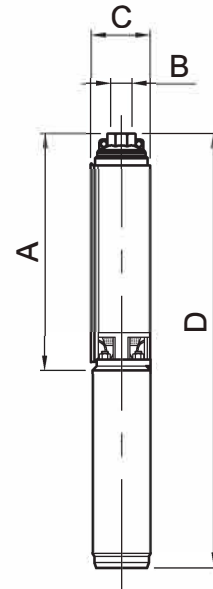
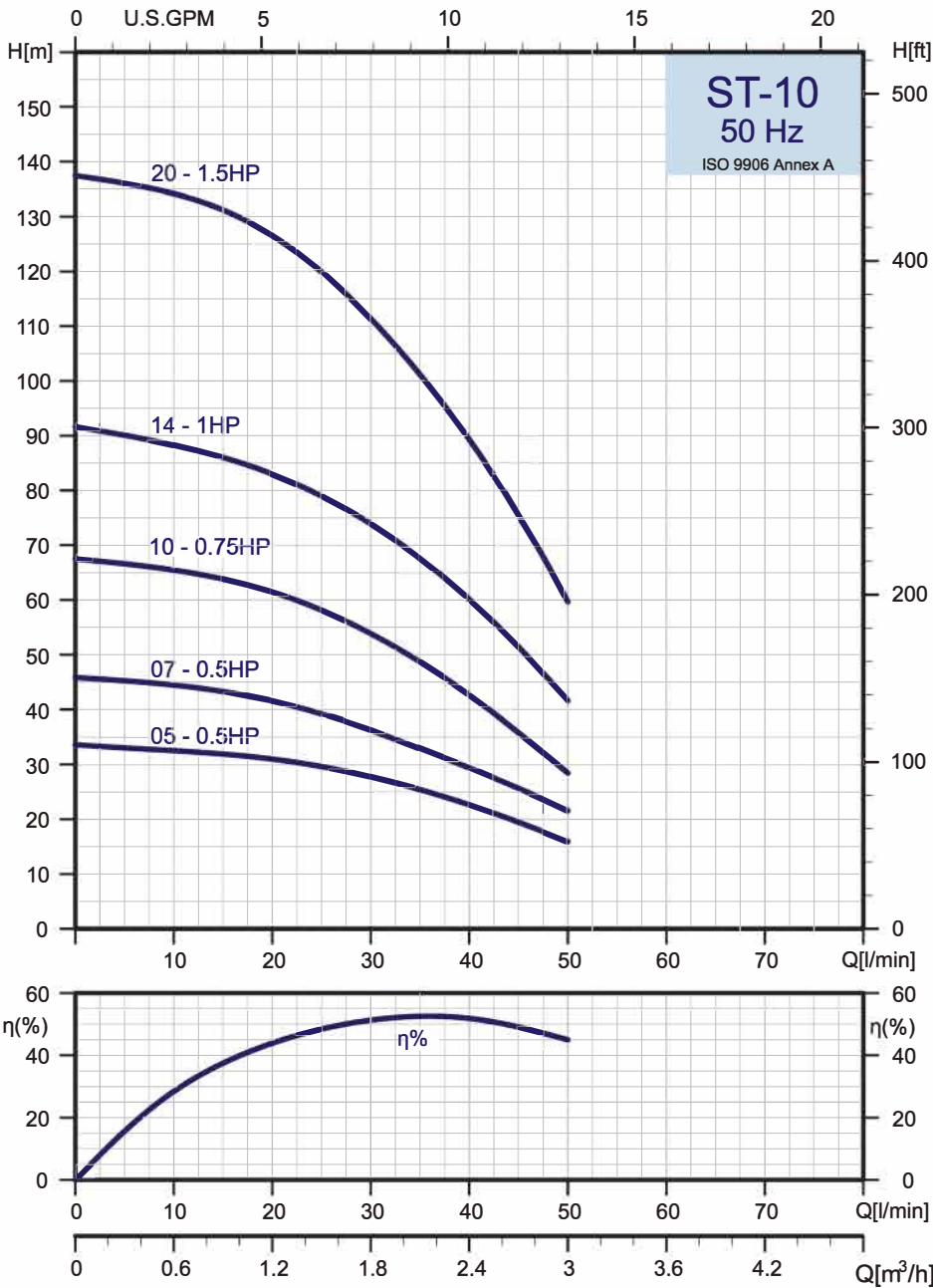

Single Phase Motor				
Dimensions and Weights				
Pump Type	Dimensions(mm)			
	A	B	C	D
ST-1005	236	RP/ NPT 1 1/4"	98	582
ST-1007	271		98	617
ST-1010	324		98	689
ST-1014	394		98	774
ST-1020	499		98	904

Three Phase Motor				
Dimensions and Weights				
Pump Type	Dimensions(mm)			
	A	B	C	D
ST-1005	236	RP/ NPT 1 1/4"	98	566
ST-1007	271		98	601
ST-1010	324		98	670
ST-1014	394		98	759
ST-1020	499		98	879

## Selection Chart

PUMP TYPE	STAGES	MOTOR		Q=DELIVERY												PUMP	ELECTRO PUMP	
				KW	HP	l/min	0	10	15	20	25	30	35	40	45		50	60
		H=TOTAL HEAD IN METERS														Single phase	Three phase	
		0	0.6	0.9	1.2	1.5	1.8	2.1	2.4	2.7	3.0	3.6						
ST-1005	5	0.37	0.5	34		32	31	29	27	25	23	19	16		2.5	9.8	9.2	
ST-1007	7	0.37	0.5	46		43	42	39	36	33	29	26	22		2.8	10.1	9.5	
ST-1010	10	0.55	0.75	67		64	61	58	54	49	43	36	28		3.3	11.5	10.7	
ST-1014	14	0.75	1.0	92		86	83	79	74	67	60	52	42		3.9	12.7	12.1	
ST-1020	20	1.1	1.5	139		131	127	120	111	101	90	75	60		4.9	14.9	13.8	

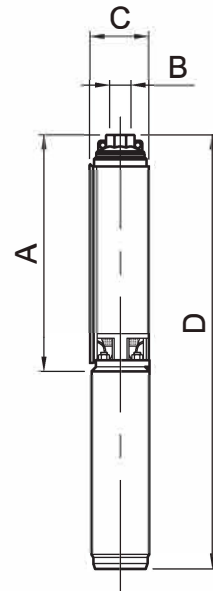
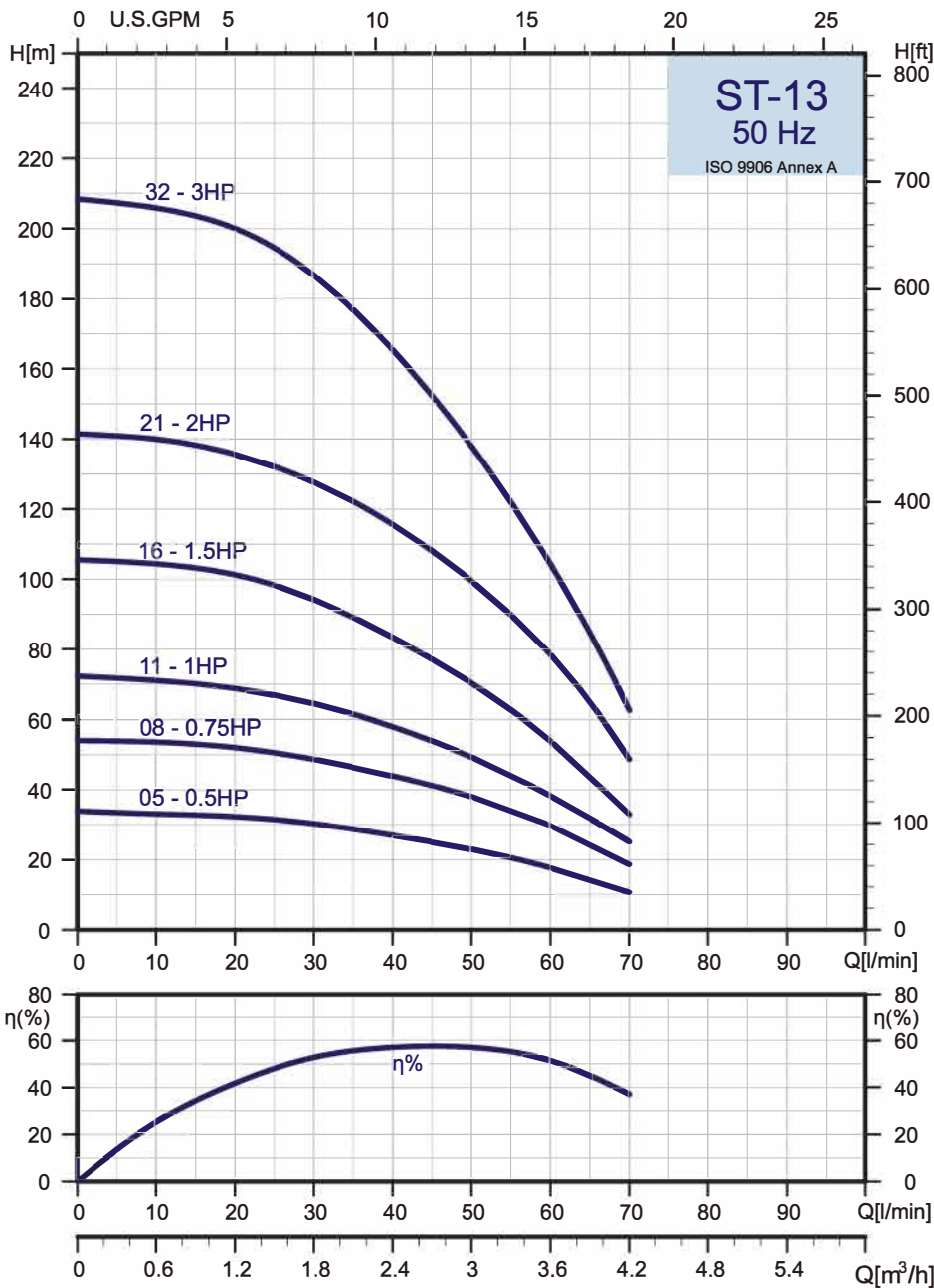

Single Phase Motor				
Dimensions and Weights				
Pump Type	Dimensions(mm)			
	A	B	C	D
ST-1305	236	RP/ NPT 1 1/4"	98	582
ST-1308	289		98	654
ST-1311	342		98	722
ST-1316	430		98	835
ST-1321	519		98	959
ST-1332	787		98	1282

Three Phase Motor				
Dimensions and Weights				
Pump Type	Dimensions(mm)			
	A	B	C	D
ST-1305	236	RP/ NPT 1 1/4"	98	566
ST-1308	289		98	635
ST-1311	342		98	707
ST-1316	430		98	810
ST-1321	519		98	924
ST-1332	787		98	1227

## Selection Chart

PUMP TYPE	STAGES	MOTOR		Q=DELIVERY													PUMP	ELECTRO PUMP	
				l/min	0	15	20	25	30	35	40	45	50	60	70	80		Net Weight(kg)	
		m³/h	0	0.9	1.2	1.5	1.8	2.1	2.4	2.7	3.0	3.6	4.2	4.8	Single phase	Three phase			
		H=TOTAL HEAD IN METERS																	
ST-1305	5	0.37	0.5	34		32	31	30	29	27	25	23	18	11		2.5	9.8	9.2	
ST-1308	8	0.55	0.75	54		51	50	49	46	43	41	38	30	19		2.9	11.1	10.3	
ST-1311	11	0.75	1.0	72		68	66	64	61	58	54	49	38	26		3.4	12.2	11.6	
ST-1316	16	1.1	1.5	106		101	98	95	89	83	77	70	54	33		4.2	14.2	13.1	
ST-1321	21	1.5	2.0	142		135	132	127	122	115	108	100	79	49		5.0	16.5	15.0	
ST-1332	32	2.2	3.0	208		200	194	187	177	165	152	138	104	62		8.1	22.1	19.7	



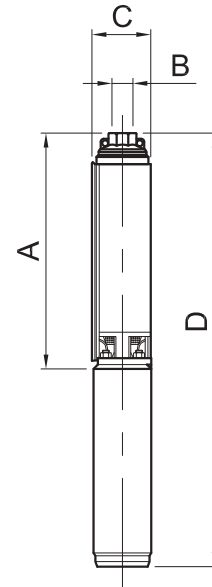
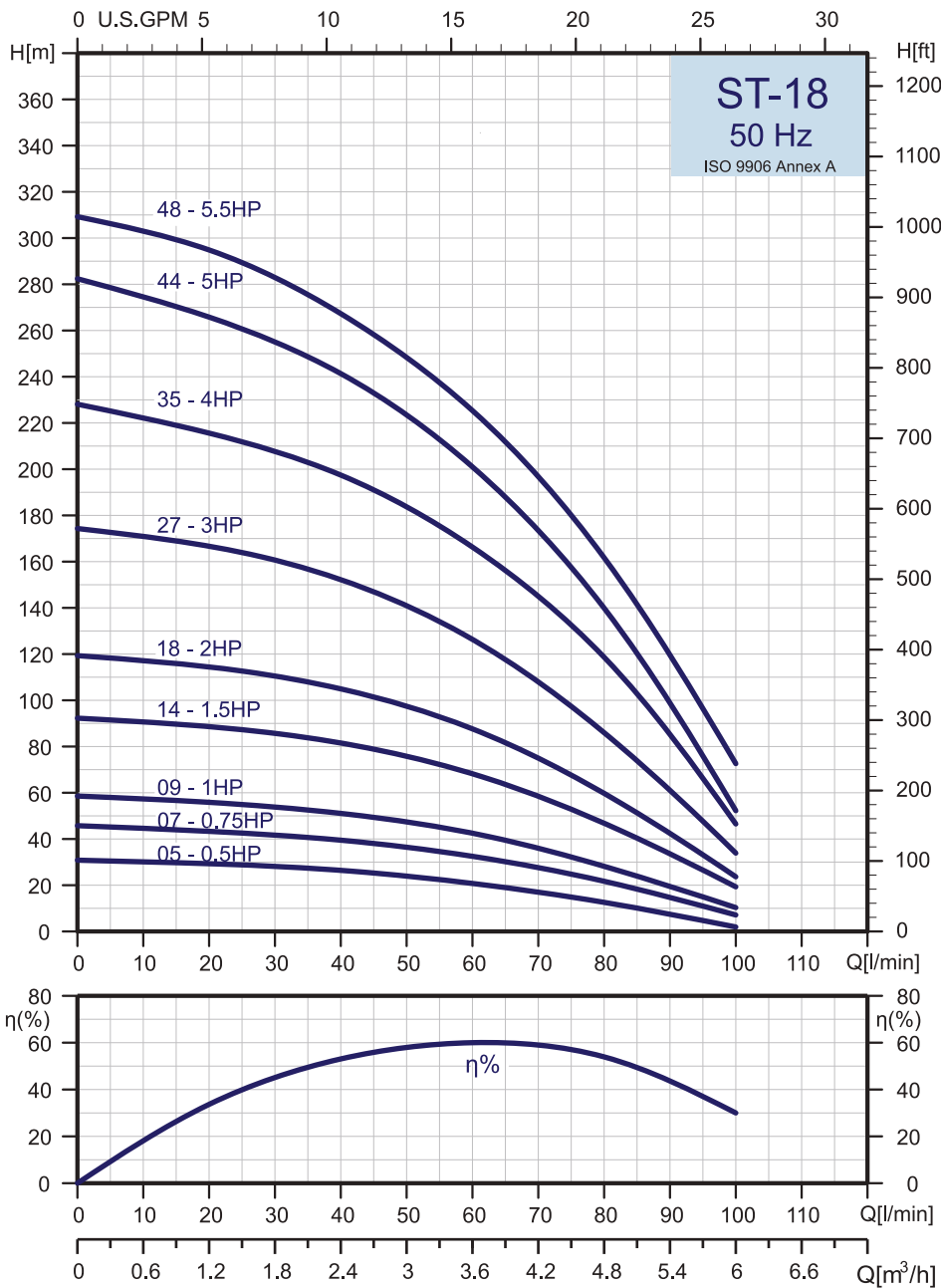

Single Phase Motor				
Dimensions and Weights				
Pump Type	Dimensions(mm)			
	A	B	C	D
ST-1805	257	RP/ NPT 1 1/4"	98	603
ST-1807	301		98	666
ST-1809	344		98	724
ST-1814	452		98	857
ST-1818	538		98	978
ST-1827	805		98	1300
ST-1835	972		98	1579
ST-1844	1166		98	1849
ST-1848	1291		98	1974

Three Phase Motor				
Dimensions and Weights				
Pump Type	Dimensions(mm)			
	A	B	C	D
ST-1805	257	RP/ NPT 1 1/4"	98	587
ST-1807	301		98	647
ST-1809	344		98	709
ST-1814	452		98	832
ST-1818	538		98	943
ST-1827	805		98	1245
ST-1835	972		98	1488
ST-1844	1166		98	1773
ST-1848	1291		98	1898

## Selection Chart

PUMP TYPE	STAGES	MOTOR		Q=DELIVERY													PUMP	ELECTRO PUMP			
				KW	HP	H=TOTAL HEAD IN METERS													Net Weight(kg)	Single phase	Three phase
		l/min	0			20	25	30	35	40	45	50	60	70	80	90	100	120			
		m³/h	0			1.2	1.5	1.8	2.1	2.4	2.7	3.0	3.6	4.2	4.8	5.4	6.0	7.2			
ST-1805	5	0.37	0.5	33		29	28	27	26	25	24	21	18	13	8	3		2.7	10.0	9.4	
ST-1807	7	0.55	0.75	46		43	42	41	39	38	36	33	28	22	15	7		3.0	11.2	10.4	
ST-1809	9	0.75	1.0	59		55	54	52	51	49	47	43	37	28	20	10		3.3	12.1	11.5	
ST-1814	14	1.1	1.5	93		87	86	83	81	79	76	68	58	47	33	20		4.1	14.1	13.0	
ST-1818	18	1.5	2.0	120		113	111	108	105	102	98	88	75	60	42	25		4.7	16.2	14.7	
ST-1827	27	2.2	3.0	175		164	161	157	152	147	141	127	109	87	61	35		7.2	21.2	18.8	
ST-1835	35	3.0	4.0	228		212	208	203	197	191	184	166	145	119	85	46		8.9	28.3	24.1	
ST-1844	44	3.7	5.0	282		261	255	249	241	233	223	201	173	140	99	52		10.3	33.0	29.8	
ST-1848	48	4.0	5.5	309		289	283	276	267	258	248	225	197	162	120	73		10.9	33.7	30.4	

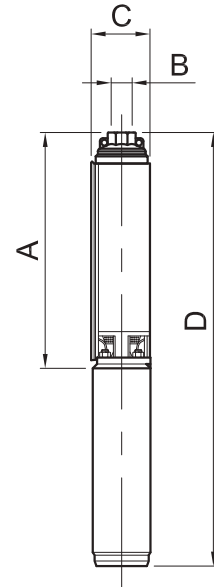
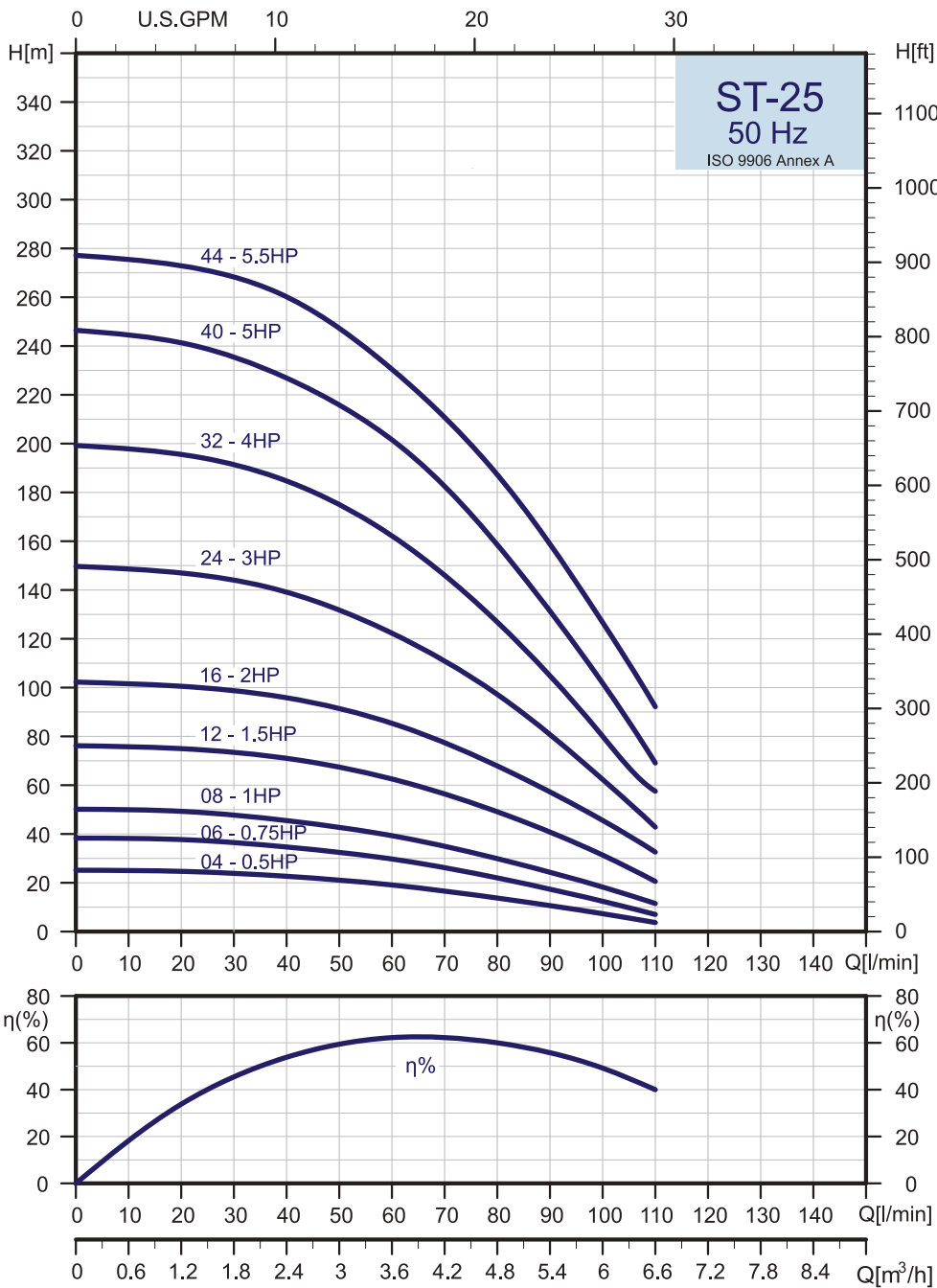

Single Phase Motor				
Dimensions and Weights				
Pump Type	Dimensions(mm)			
	A	B	C	D
ST-2504	247	RP/ NPT 1 1/2"	98	593
ST-2506	296		98	661
ST-2508	345		98	725
ST-2512	433		98	838
ST-2516	542		98	982
ST-2524	815		98	1310
ST-2532	1003		98	1610
ST-2540	1198		98	1881
ST-2544	1334		98	2071

Three Phase Motor				
Dimensions and Weights				
Pump Type	Dimensions(mm)			
	A	B	C	D
ST-2504	247	RP/ NPT 1 1/2"	98	577
ST-2506	296		98	642
ST-2508	345		98	710
ST-2512	433		98	813
ST-2516	542		98	947
ST-2524	815		98	1255
ST-2532	1003		98	1519
ST-2540	1198		98	1805
ST-2544	1334		98	1941

## Selection Chart

PUMP TYPE	STAGES	MOTOR		Q=DELIVERY													PUMP	ELECTRO PUMP	
				l/min	0	30	35	40	45	50	60	70	80	90	100	120		Net Weight(kg)	
		KW	HP	m³/h	0	1.8	2.1	2.4	2.7	3.0	3.6	4.2	4.8	5.4	6.0	7.2	Single phase	Three phase	
		H=TOTAL HEAD IN METERS																	
ST-2504	4	0.37	0.5	26		23	22	22	21	19	17	14	11	7		2.4	9.7	9.1	
ST-2506	6	0.55	0.75	38		36	35	33	32	30	26	22	18	12		2.9	11.1	10.3	
ST-2508	8	0.75	1.0	51		47	46	44	43	39	35	30	24	18		3.3	12.1	11.5	
ST-2512	12	1.1	1.5	77		72	71	69	68	63	57	49	41	31		4.1	14.1	13	
ST-2516	16	1.5	2.0	102		98	96	94	92	86	77	68	57	46		5.0	16.5	15	
ST-2524	24	2.2	3.0	151		142	139	136	132	122	111	97	80	62		7.6	21.6	19.2	
ST-2532	32	3.0	4.0	203		188	185	180	175	162	146	127	105	80		9.7	29.1	24.9	
ST-2540	40	3.7	5.0	253		232	227	222	216	202	182	159	131	102		11.4	34.1	30.9	
ST-2544	44	4.0	5.5	278		265	260	254	247	230	210	187	159	127		12.2	35.0	31.7	

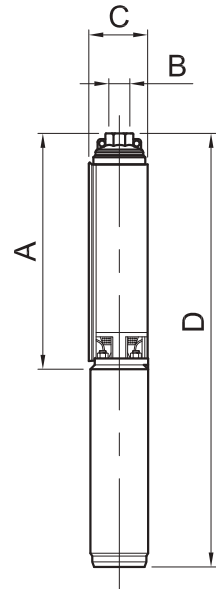
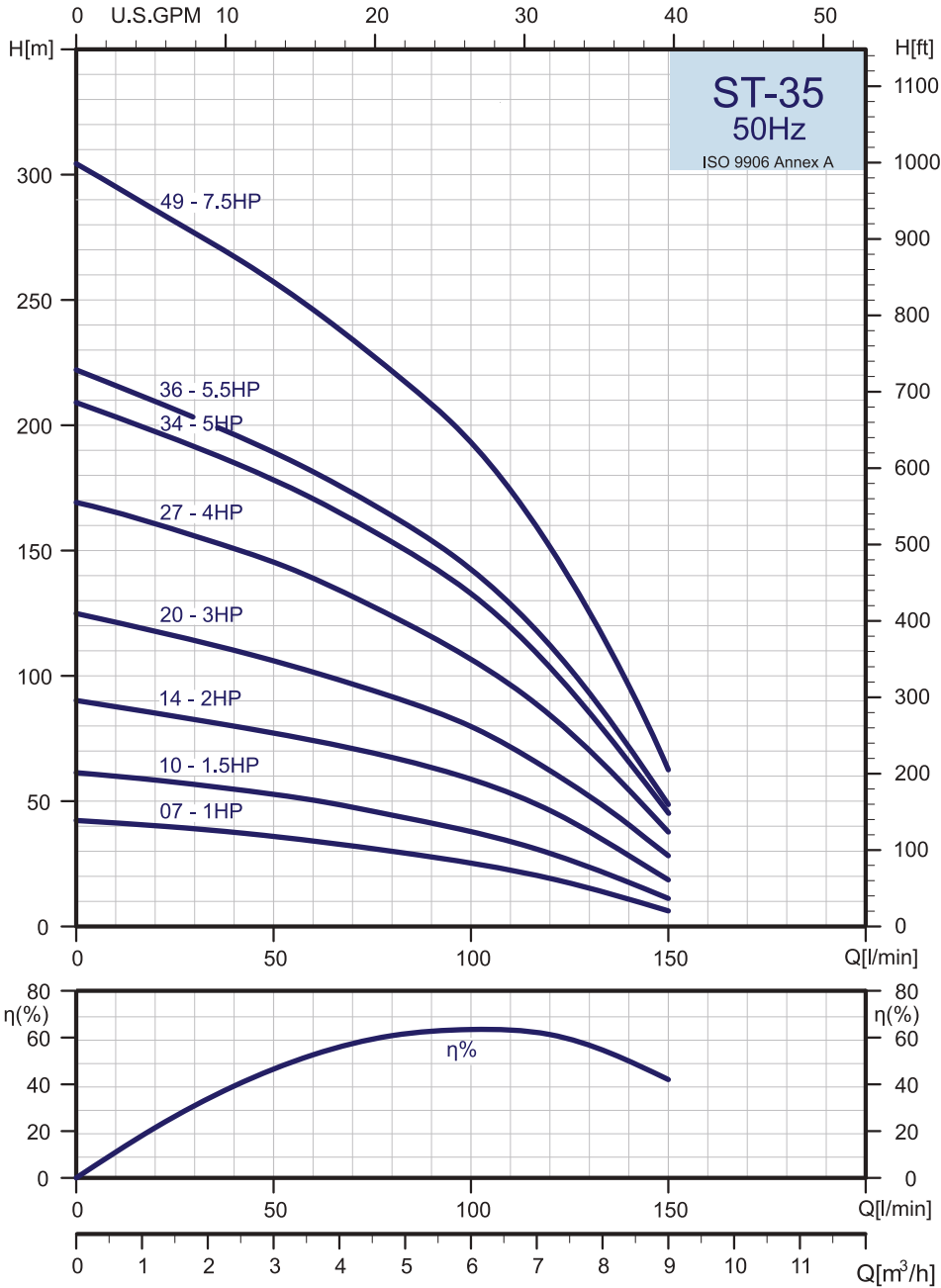

Single Phase Motor				
Dimensions and Weights				
Pump Type	Dimensions(mm)			
	A	B	C	D
ST-3507	390	RP/ NPT 2"	98	770
ST-3510	483		98	888
ST-3514	607		98	1012
ST-3520	831		98	1326
ST-3527	1086		98	1693
ST-3534	1295		98	1978
ST-3536	1356		98	2039
ST-3549	1840		98	N/A

Three Phase Motor				
Dimensions and Weights				
Pump Type	Dimensions(mm)			
	A	B	C	D
ST-3507	390	RP/ NPT 2"	98	755
ST-3510	483		98	863
ST-3514	607		98	1012
ST-3520	831		98	1271
ST-3527	1086		98	1602
ST-3534	1295		98	1902
ST-3536	1356		98	1963
ST-3549	1840		98	2523

## Selection Chart

PUMP TYPE	STAGES	MOTOR		Q=DELIVERY													PUMP	ELECTRO PUMP	
				l/min	0	45	50	60	70	80	90	100	120	140	160	Net Weight(kg)			
		0	2.7	3.0	3.6	4.2	4.8	5.4	6.0	7.2	8.4	9.6	Single phase	Three phase					
		H=TOTAL HEAD IN METERS																	
ST-3507	7	0.75	1.0	42		36	34	32	30	28	25	19	11		3.7	12.5	11.9		
ST-3510	10	1.1	1.5	62		53	51	48	45	41	38	29	18		4.6	14.6	13.5		
ST-3514	14	1.5	2.0	90		77	74	71	68	63	59	46	28		5.7	17.2	15.7		
ST-3520	20	2.2	3.0	125		107	102	97	92	86	80	62	40		7.5	21.5	19.1		
ST-3527	27	3.0	4.0	169		145	139	131	123	115	107	84	55		10.6	30.0	25.8		
ST-3534	34	3.7	5.0	208		178	170	162	153	143	132	103	66		12.6	35.3	32.1		
ST-3536	36	4	5.5	221		190	181	173	164	154	143	112	72		13.2	36.0	32.7		
ST-3549	49	5.5	7.5	302		257	246	234	222	209	193	151	96		16.9	N/A	40.0		

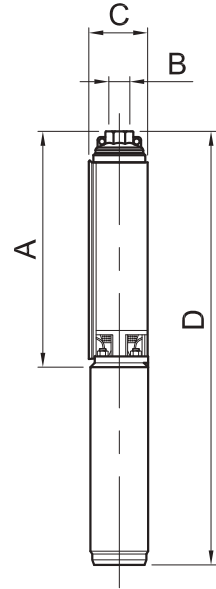
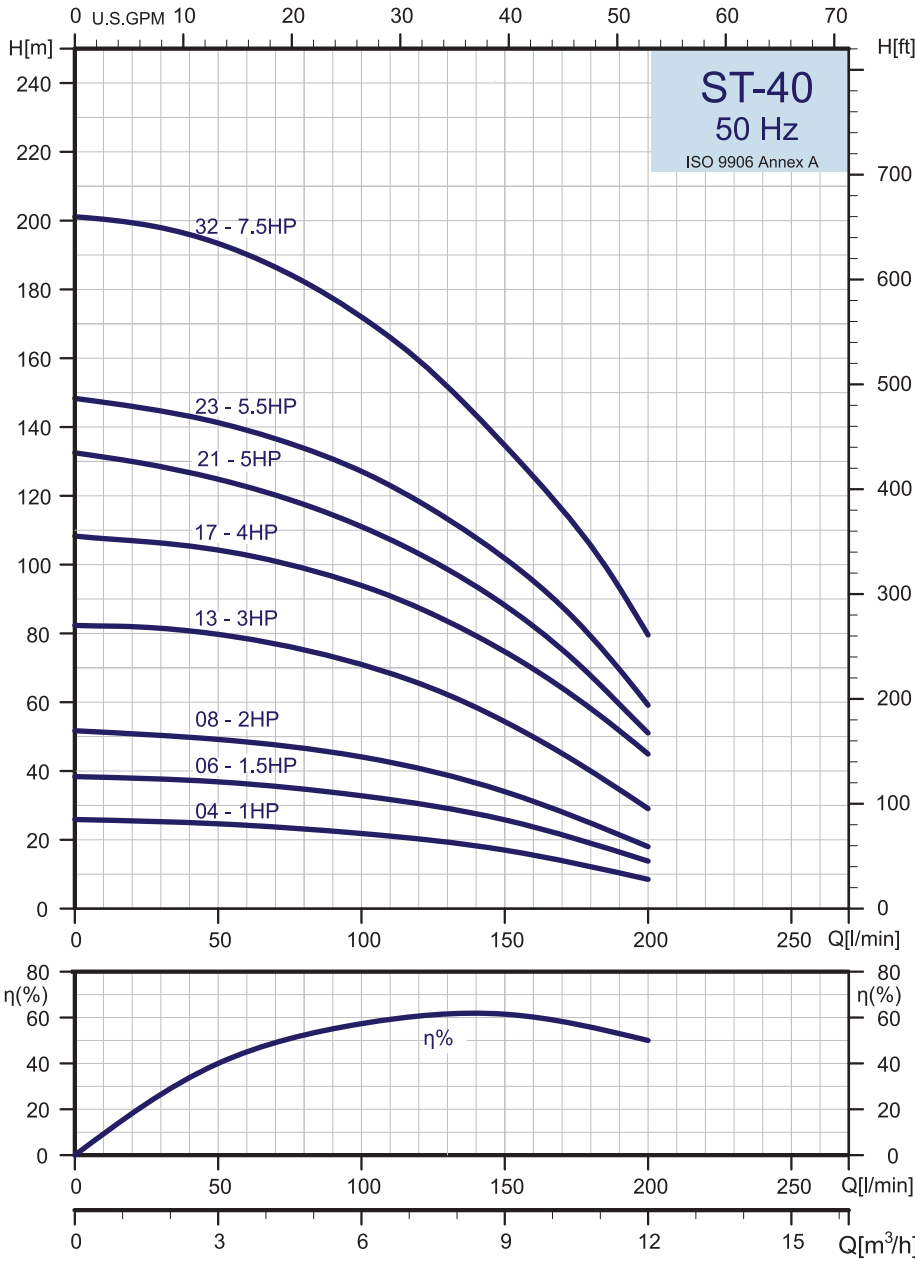

Single Phase Motor				
Dimensions and Weights				
Pump Type	Dimensions(mm)			
	A	B	C	D
ST-4004	294	RP/ NPT 2"	98	674
ST-4006	356		98	761
ST-4008	418		98	858
ST-4013	573		98	1068
ST-4017	697		98	1304
ST-4021	859		98	1542
ST-4023	959		98	1642
ST-4032	1276		98	N/A

Three Phase Motor				
Dimensions and Weights				
Pump Type	Dimensions(mm)			
	A	B	C	D
ST-4004	294	RP/ NPT 2"	98	659
ST-4006	356		98	736
ST-4008	418		98	823
ST-4013	573		98	1013
ST-4017	697		98	1213
ST-4021	859		98	1466
ST-4023	959		98	1566
ST-4032	1276		98	1595

## Selection Chart

PUMP TYPE	STAGES	MOTOR		Q=DELIVERY												PUMP	ELECTRO PUMP	
				l/min	70	80	90	100	120	140	160	180	200	220	Net Weight(kg)			
		KW	HP	m³/h	4.2	4.8	5.4	6.0	7.2	8.4	9.6	10.8	12	13.2	Single phase	Three phase		
		H=TOTAL HEAD IN METERS																
ST-4004	4	0.75	1.0	26		23	22	21	20	18	16	12	9		2.8	11.6	11	
ST-4006	6	1.1	1.5	38		35	34	33	31	28	24	19	14		3.4	13.4	12.3	
ST-4008	8	1.5	2.0	52		47	45	44	41	37	31	25	18		4.0	15.5	14.0	
ST-4013	13	2.2	3.0	82		75	73	71	66	59	50	40	30		5.5	19.5	17.1	
ST-4017	17	3.0	4.0	108		98	96	94	87	79	70	58	46		6.6	26.0	21.8	
ST-4021	21	3.7	5.0	132		117	114	111	103	93	82	68	52		7.8	30.5	27.3	
ST-4023	23	4.0	5.5	148		134	131	127	118	108	95	79	60		9.4	32.2	28.9	
ST-4032	32	5.5	7.5	202		182	178	172	160	143	125	105	80		12.0	N/A	35.1	

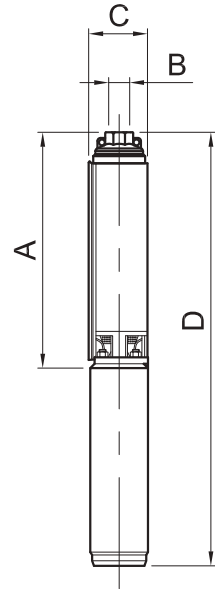
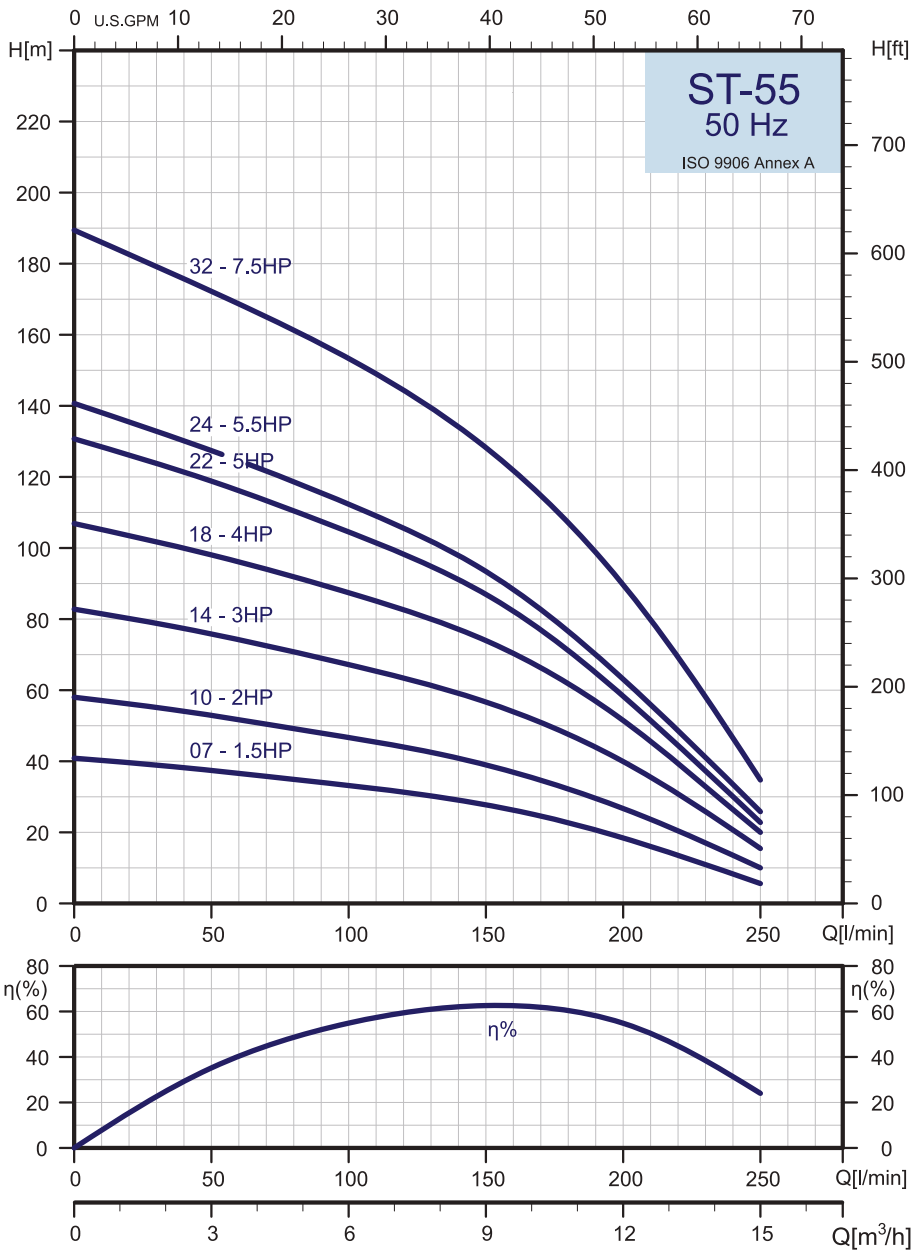

Single Phase Motor				
Dimensions and Weights				
Pump Type	Dimensions(mm)			
	A	B	C	D
ST-5507	537	RP/ NPT 2"	98	942
ST-5510	693		98	1133
ST-5514	901		98	1496
ST-5518	1185		98	1792
ST-5522	1383		98	2066
ST-5524	1487		98	2170
ST-5532	1904		98	N/A

Three Phase Motor				
Dimensions and Weights				
Pump Type	Dimensions(mm)			
	A	B	C	D
ST-5507	537	RP/ NPT 2"	98	917
ST-5510	693		98	1098
ST-5514	901		98	1341
ST-5518	1185		98	1701
ST-5522	1383		98	1990
ST-5524	1487		98	2094
ST-5532	1904		98	2587

## Selection Chart

PUMP TYPE	STAGES	MOTOR		Q=DELIVERY														PUMP	ELECTRO PUMP	
				KW	HP	l/min	70	80	90	100	120	140	160	180	200	220	240		260	Net Weight(kg)
		H=TOTAL HEAD IN METERS																Single phase	Three phase	
		m³/h	0	4.2	4.8	5.4	6.0	7.2	8.4	9.6	10.8	12	13.2	14.4	15.6					
ST-5507	7	1.1	1.5	41		35	34	33	32	29	26	23	18	14	8		5.3	15.3	14.2	
ST-5510	10	1.5	2.0	58		49	48	47	44	41	37	32	27	20	13		6.7	18.2	16.7	
ST-5514	14	2.2	3.0	83		71	69	67	63	58	54	48	40	31	20		8.5	22.5	20.1	
ST-5518	18	3.0	4.0	107		92	90	87	83	77	70	62	52	39	26		11.4	30.8	26.6	
ST-5522	22	3.7	5.0	131		110	107	104	98	91	82	71	58	45	30		13.3	36.0	32.8	
ST-5524	24	4.0	5.5	141		118	116	113	106	97	88	77	63	49	33		14.2	37.0	33.7	
ST-5532	32	5.5	7.5	189		162	157	153	144	134	122	107	90	70	47		18.0	N/A	41.1	

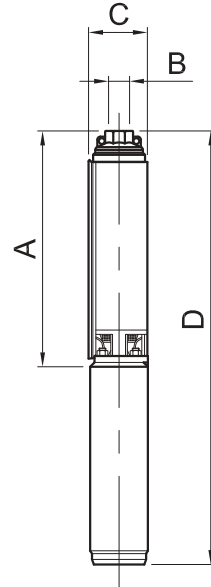
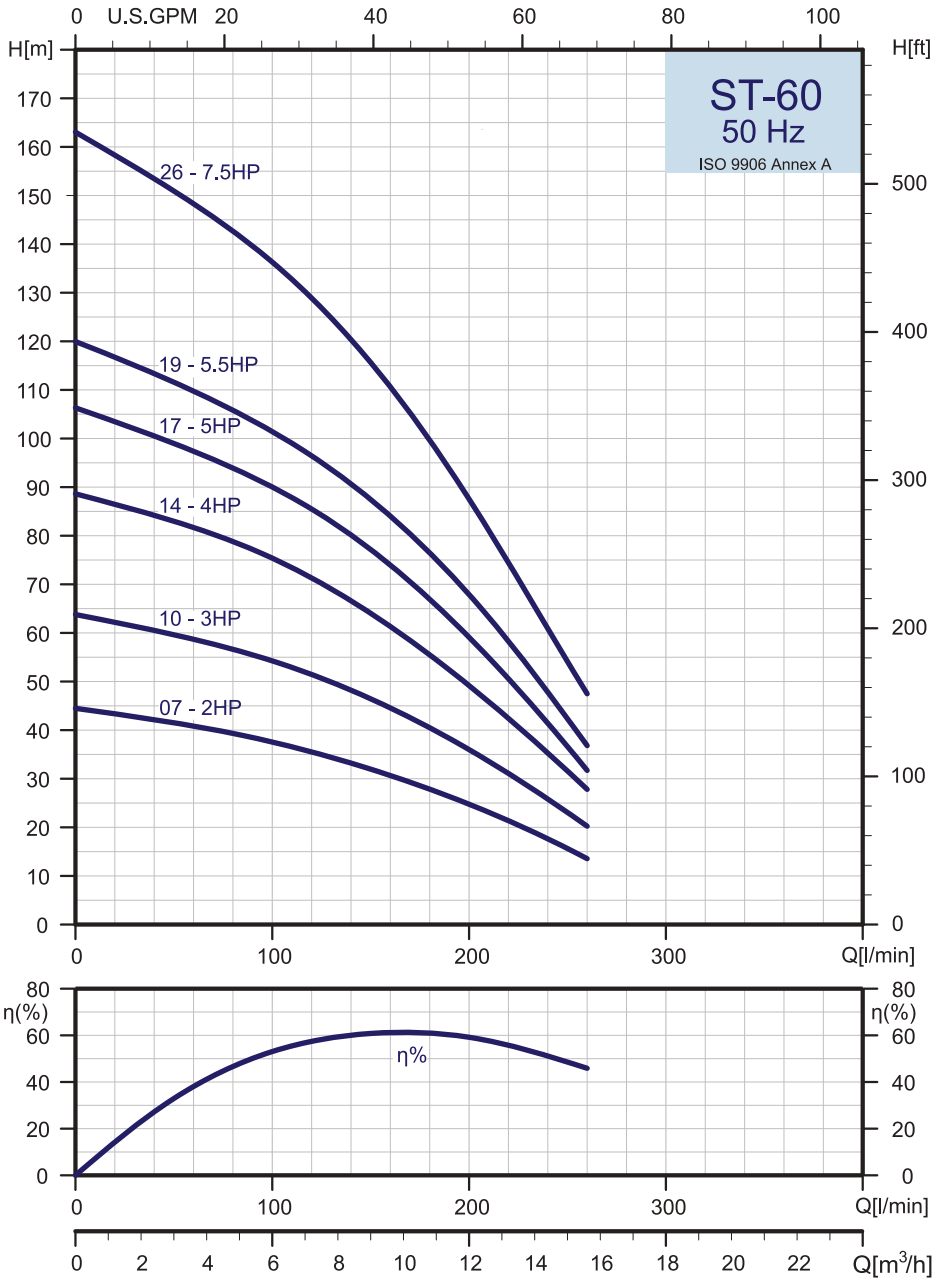

Single Phase Motor				
Dimensions and Weights				
Pump Type	Dimensions(mm)			
	A	B	C	D
ST-6007	534	RP/ NPT 2"	98	974
ST-6010	690		98	1185
ST-6014	989		98	1596
ST-6017	1092		98	1775
ST-6019	1233		98	1916
ST-6026	1597		98	N/A

Three Phase Motor				
Dimensions and Weights				
Pump Type	Dimensions(mm)			
	A	B	C	D
ST-6007	534	RP/ NPT 2"	98	939
ST-6010	690		98	1130
ST-6014	989		98	1505
ST-6017	1092		98	1699
ST-6019	1233		98	1840
ST-6026	1597		98	2280

## Selection Chart

PUMP TYPE	STAGES	MOTOR		Q=DELIVERY													PUMP	ELECTRO PUMP	
				l/min	90	100	120	140	160	180	200	220	240	260	280	Net Weight(kg)		Single phase	Three phase
		m³/h	0	5.4	6.0	7.2	8.4	9.6	10.8	12	13.2	14.4	15.6	16.8					
		H=TOTAL HEAD IN METERS																	
ST-6007	7	1.5	2.0	45		37	36	33	31	28	25	22	18	14		5.3	16.8	15.3	
ST-6010	10	2.2	3.0	64		54	52	48	44	41	36	32	26	20		6.7	20.7	18.3	
ST-6014	14	3.0	4.0	89		76	72	67	62	56	49	43	35	28		8.6	28.0	23.8	
ST-6017	17	3.7	5.0	107		90	86	80	74	67	59	51	42	32		10.1	32.8	29.6	
ST-6019	19	4.0	5.5	120		102	97	91	89	76	68	58	48	37		12.0	34.8	31.5	
ST-6026	26	5.5	7.5	163		136	129	120	111	100	87	75	61	48		15.3	N/A	38.4	

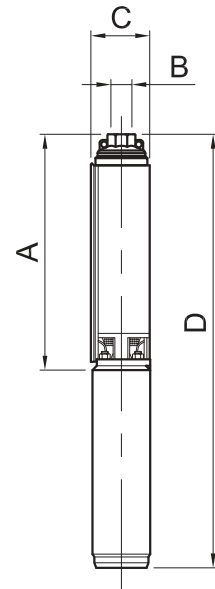
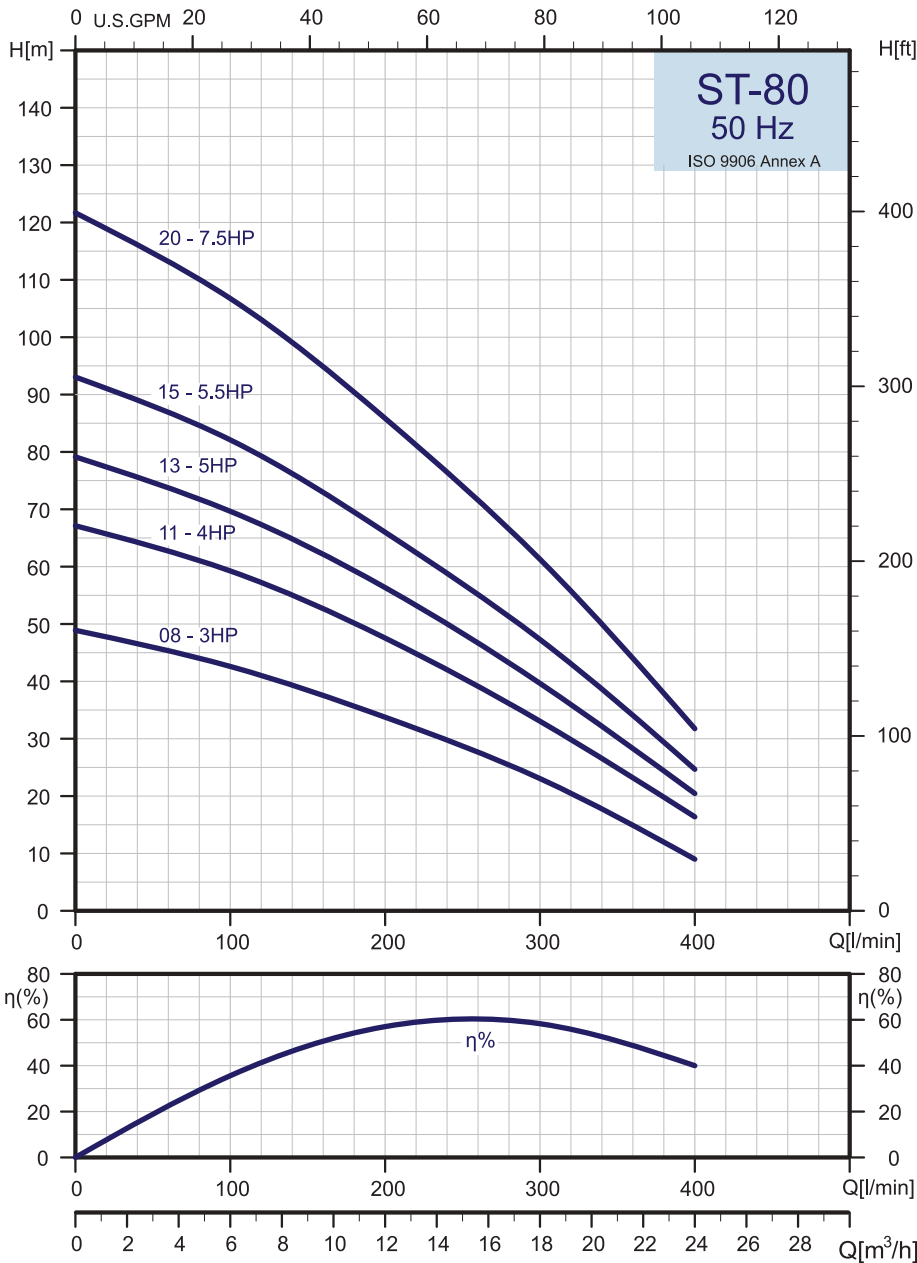

Single Phase Motor				
Dimensions and Weights				
Pump Type	Dimensions(mm)			
	A	B	C	D
ST-8008	676	RP/ NPT 2"	98	1171
ST-8011	880		98	1487
ST-8013	1013		98	1696
ST-8015	1149		98	1832
ST-8020	1489		98	N/A

Three Phase Motor				
Dimensions and Weights				
Pump Type	Dimensions(mm)			
	A	B	C	D
ST-8008	676	RP/ NPT 2"	98	1116
ST-8011	880		98	1396
ST-8013	1013		98	1620
ST-8015	1149		98	1756
ST-8020	1489		98	2172

## Selection Charts

PUMP TYPE	STAGES	MOTOR		Q=DELIVERY																	PUMP	ELECTRO PUMP	
				l/min	0	120	140	160	180	200	220	240	260	280	300	320	340	360	380	400		450	Net Weight(kg)
		HP	m³/h	0	7.2	8.4	9.6	10.8	12	13.2	14.4	15.6	16.8	18	19.2	20.4	21.6	22.8	24	27	Single phase	Three phase	
		H=TOTAL HEAD IN METERS																					
ST-8008	8	2.2	3.0	49		39	38	36	34	32	30	28	25	23	20	18	15	12	9		6.3	20.3	17.9
ST-8011	11	3.0	4.0	67		55	53	50	48	45	42	39	36	33	30	27	23	20	16		8.1	27.5	23.3
ST-8013	13	3.7	5.0	79		65	62	59	56	53	50	47	43	40	36	32	28	24	20		9.3	32.0	28.8
ST-8015	15	4.0	5.5	93		76	73	70	66	62	59	55	51	47	43	39	34	29	25		10.5	33.3	30.0
ST-8020	20	5.5	7.5	122		99	95	90	86	81	76	72	67	61	56	50	44	38	32		13.5	N/A	36.6



## SISTEMA 6" ST Submersible Pumps

### Description

The 6" submersible pumps for high pressures and flow rates, particularly equipped with a high rigidity

**Silicon-Carbide(SIC) Bearing,** provide reliability and quality guaranteed.

**Discharge Head and Motor Adaptor** are precision machined cast 304 stainless steel for superior strength and durability. The motor adaptor is NEMA standard.

**Impellers** are made with Noryl® For a superior sand handling.

Together with glass filled polycarbonate diffusers make the super strong pumps for maximum wear and abrasive resistance. The materials are FDA compliant materials.

**Impeller Bowls** are made from 304 stainless steel, maximizing wear from abrasion.

**Shaft Coupling** is made from 304 stainless steel for easy alignment to the motor shaft.

**Strainer** is made from stamped 304 stainless steel for rigidity.

**Non-Return valve** made from 304 stainless steel, fitted in the discharge to prevent any back flow of water and alleviate any water hammer to the pumps.

**Pump Shaft** is made from hex 304 stainless steel bar material for high corrosion resistance.

**Pump body** is covered by a thick 304 stainless steel casing, ensures optimum resistance to abrasion.

### APPLICATIONS

- Water Supply
- Irrigation
- Pressure Boosting

### GENERAL SPECIFICATIONS PUMP

- Delivery: up to 60 m<sup>3</sup> /h at 2850 rpm
- Head: up to 466 m at 2850 rpm
- Maximum permissible quantity of sand: 50g/m<sup>3</sup>
- ST 50-ST75-ST135-ST180-ST220 models 3" discharge.



**Performance Range**

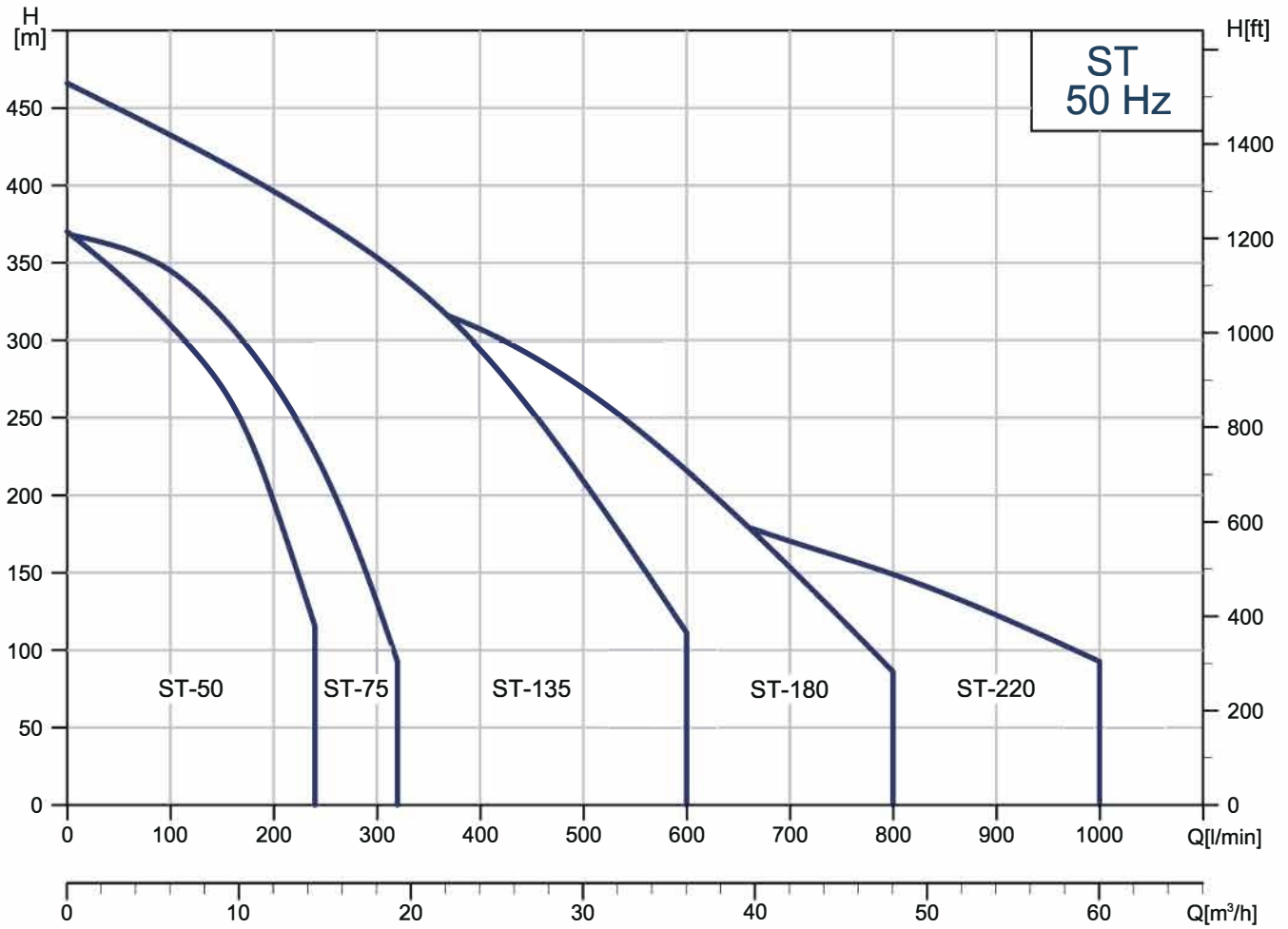

## Material Specification

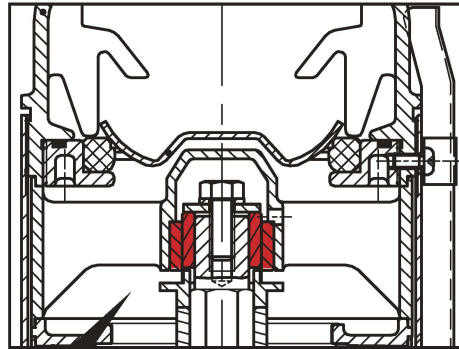
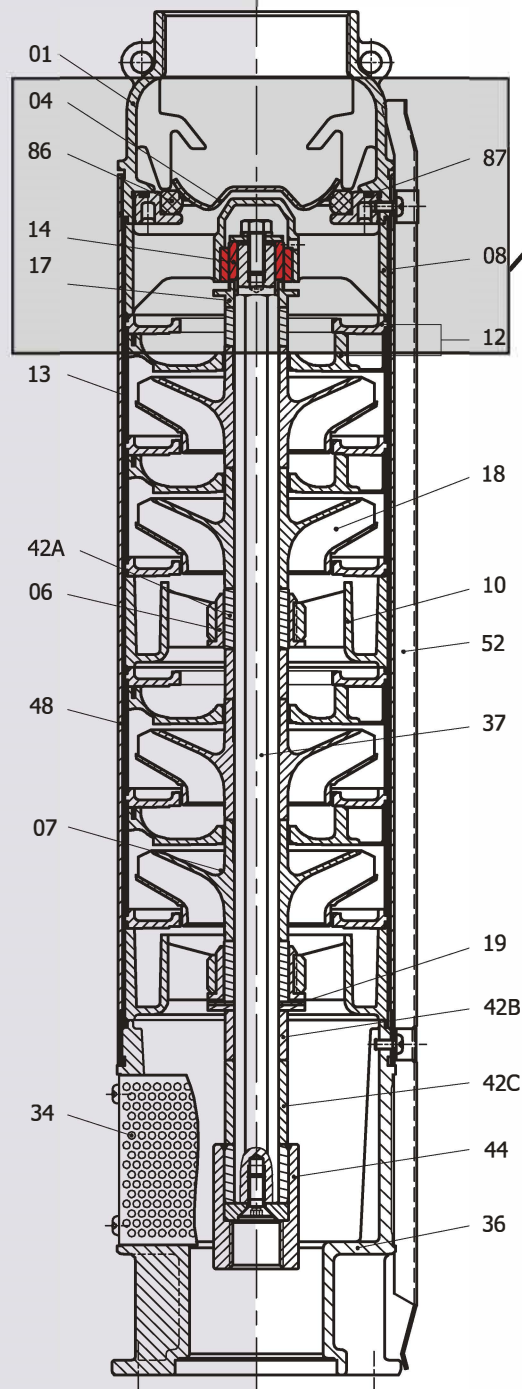

High rigidity **Silicon-Carbide(SiC) Bearing** ensure high corrosion resistance and provide long and dependable service life.

Pos.	Part Name	Material
01	Discharge	AISI 304
04	Valve cone	AISI 304
06	Bearing	POM+PTFE
07	Bearing	Bronze
08	Upper bearing spider	AISI 304 + Silicon carbide
10	Bearing Spider	Noryl
12	Diffuser	Glass Filled Polycarbonate
13	Diffuser casing	AISI 304
14	Bearing ring	Silicon carbide
17	Sleeve for baffle	AISI 304
18	Impeller	Noryl
19	Counter thrust bearing plate	Carbon fiber + PTFE
34	Strainer	AISI 304
36	Suction interconnector	AISI 304
37	Pump shaft	AISI 304
42A	Shaft sleeve	AISI 304
42B	Shaft sleeve	Noryl
42C	Shaft sleeve	Noryl
44	Coupling	AISI 304
48	Pump casing	AISI 304
52	Cable guard	AISI 304
86	Valve Seat	AISI 304 + NBR
87	O-ring	NBR

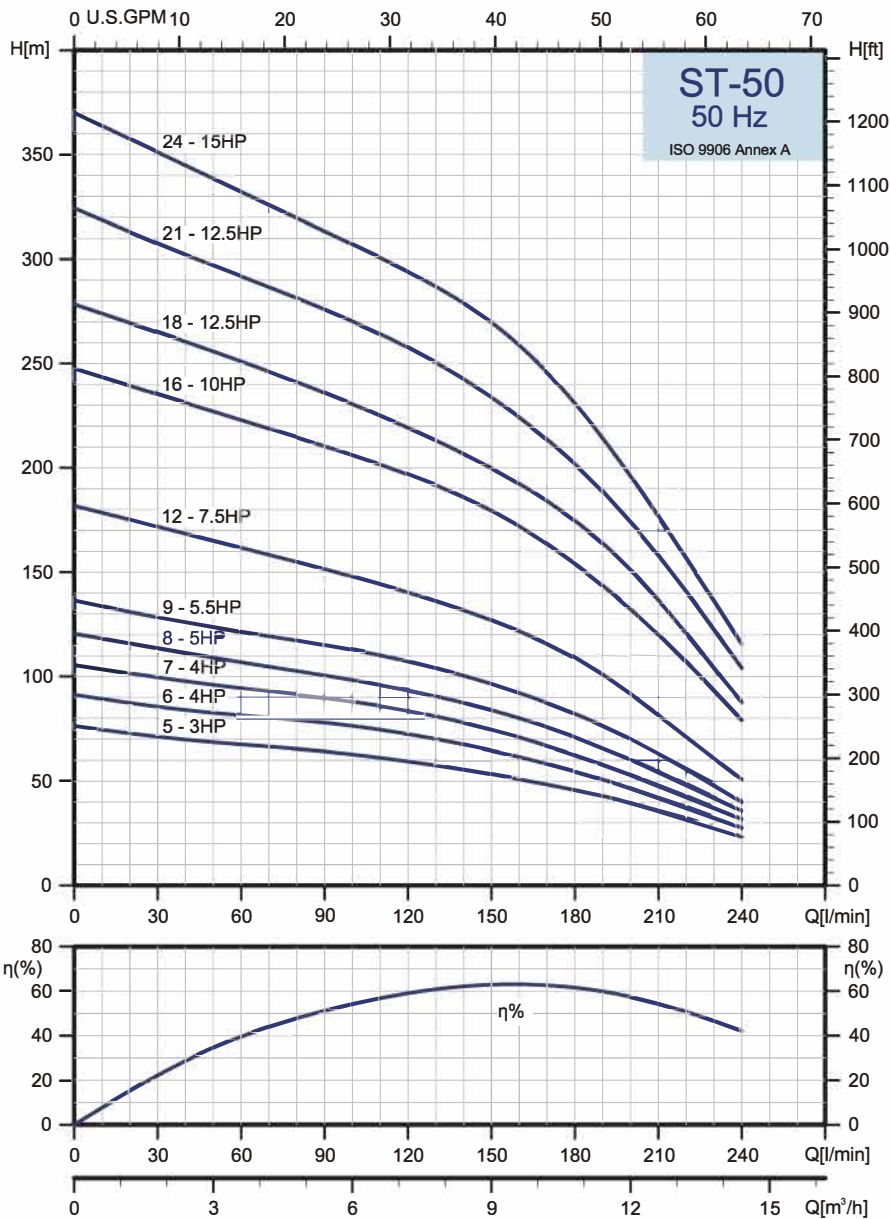

### Product data

Pump Type	HP	Q(m <sup>3</sup> /h)	H(m)	Hmax(m)
ST 50-05	3	9.5	52	77
ST 50-06	4	9.5	62	92
ST 50-07	4	9.5	72	106
ST 50-08	5	9.5	81	121
ST 50-09	5.5	9.5	93	137
ST 50-12	7.5	9.5	123	182
ST 50-16	10	9.5	174	248
ST 50-18	12.5	9.5	194	279
ST 50-21	12.5	9.5	226	325
ST 50-24	15	9.5	261	371

### Dimensions and weights

Pump type	Motor			Dimensions(mm)					Weight(kg) Pump	
	Power		Type	A	B	C	C*	C**		
kW	HP									
ST 50-5	2.2	3	4"	539	NPT3" RP3"	138			10.3	
ST 50-6	3	4	4"	577		138			11.1	
ST 50-7	3	4	4"	615		138			11.8	
ST 50-8	3.7	5	4"	653		138			12.5	
ST 50-9	4	5.5	4"	691		138			13.1	
ST 50-12	5.5	7.5	4"	805		138			15	
ST 50-16	7.5	10	4"	957		138			17.7	
ST 50-12	5.5	7.5	6"	819				141	144	15.9
ST 50-16	7.5	10	6"	971				141	144	18.7
ST 50-18	9.3	12.5	6"	1047				141	144	20
ST 50-21	9.3	12.5	6"	1161				141	144	21.9
ST 50-24	11	15	6"	1275				141	144	24

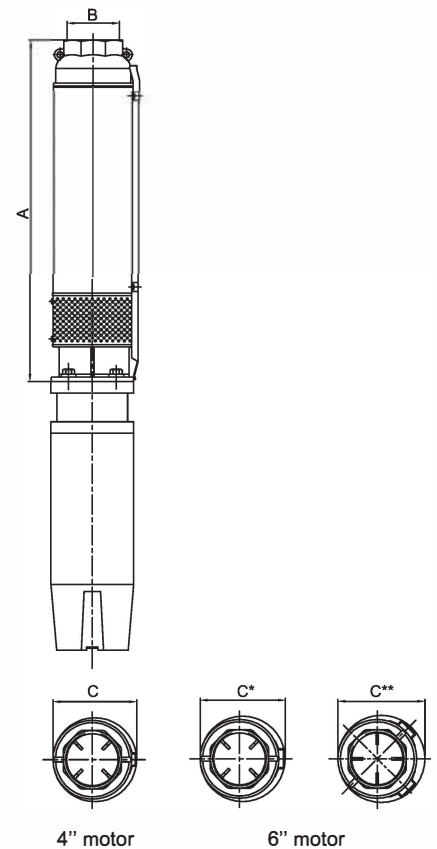

4" motor

6" motor

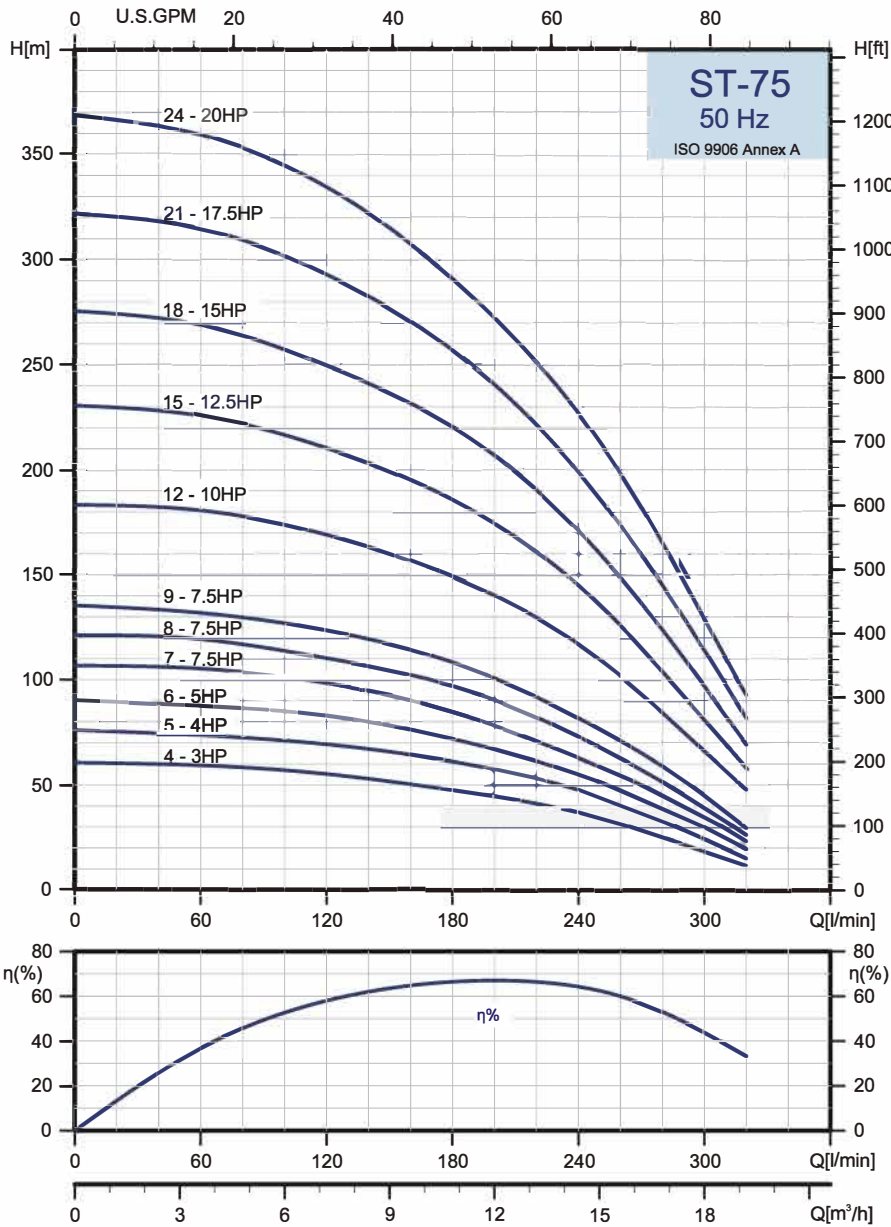

### Product data

Pump Type	HP	Q(m³/h)	H(m)	Hmax(m)
ST 75-04	3	14	39	61
ST 75-05	4	14	50	77
ST 75-06	5	14	57	91
ST 75-07	7.5	14	66	107
ST 75-08	7.5	14	76	122
ST 75-09	7.5	14	86	136
ST 75-12	10	14	122	184
ST 75-15	12.5	14	151	231
ST 75-18	15	14	178	276
ST 75-21	17.5	14	207	323
ST 75-24	20	14	236	369

### Dimensions and weights

Pump type	Motor			Dimensions(mm)					Weight(kg)
	Power		Type	A	B	C	C*	C**	
	kW	HP							
ST 75-4	2.2	3	4"	501	NPT3" RP3"	138			9.6
ST 75-5	3	4	4"	539		138			10.3
ST 75-6	3.7	5	4"	577		138			11
ST 75-7	5.5	7.5	4"	615		138			11.7
ST 75-8	5.5	7.5	4"	653		138			12.5
ST 75-9	5.5	7.5	4"	691		138			13.1
ST 75-12	7.5	10	4"	805		138			15
ST 75-7	5.5	7.5	6"	629			141	144	12.5
ST 75-8	5.5	7.5	6"	667			141	144	13.2
ST 75-9	5.5	7.5	6"	705			141	144	13.9
ST 75-12	7.5	10	6"	819			141	144	15.8
ST 75-15	9.3	12.5	6"	933			141	144	17.8
ST 75-18	11	15	6"	1047			141	144	19.9
ST 75-21	13	17.5	6"	1161			141	144	21.8
ST 75-24	15	20	6"	1275		141	144	23.8	

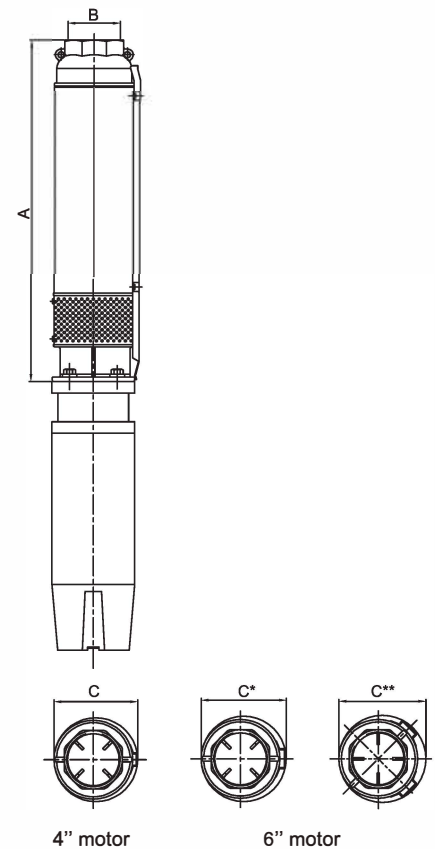

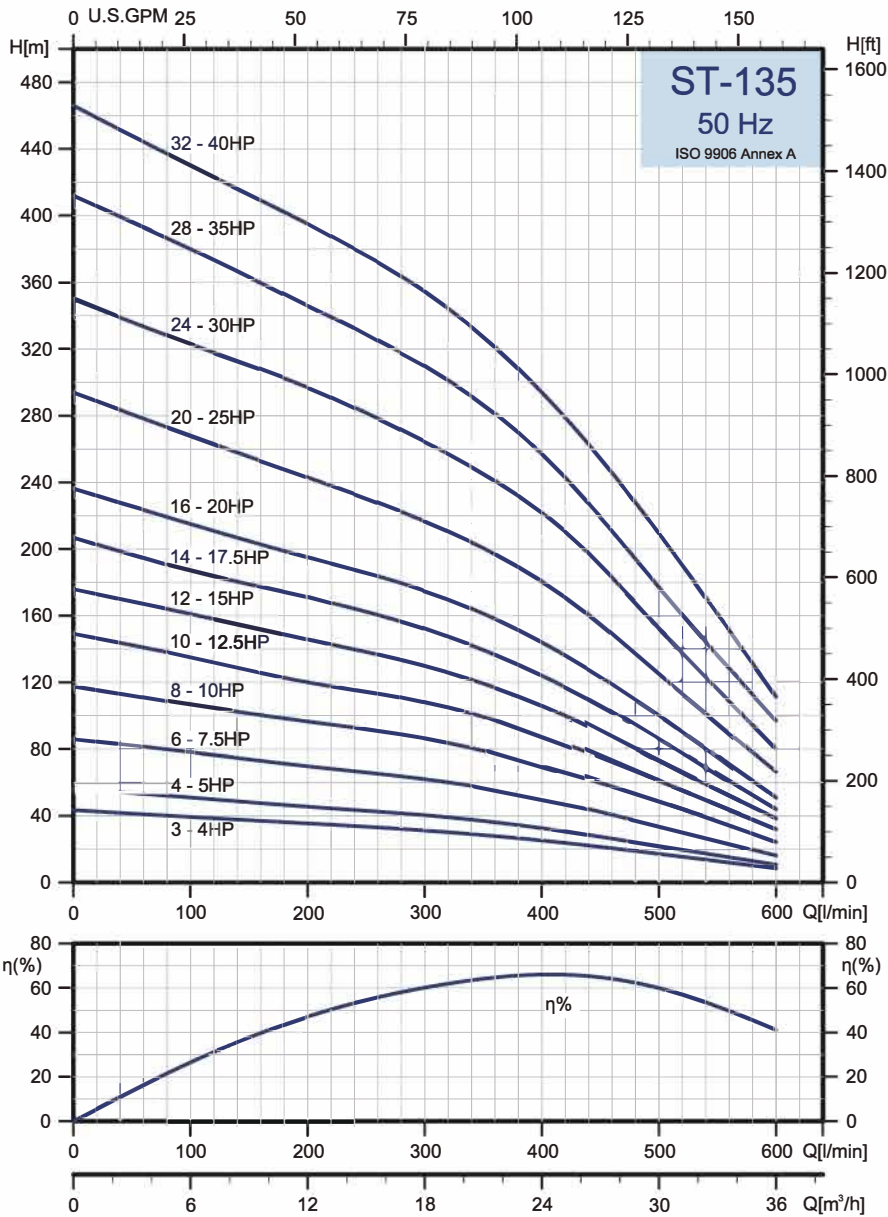

### Product data

Pump Type	HP	Q(m³/h)	H(m)	Hmax(m)
ST 135-03	4	25	24	44
ST 135-04	5	25	31	57
ST 135-06	7.5	25	48	86
ST 135-08	10	25	67	118
ST 135-10	12.5	25	84	150
ST 135-12	15	25	101	176
ST 135-14	17.5	25	119	207
ST 135-16	20	25	138	237
ST 135-20	25	25	173	294
ST 135-24	30	25	213	350
ST 135-28	35	25	246	412
ST 135-32	40	25	282	466

### Dimensions and weights

Pump type	Motor			Dimensions(mm)					Weight(kg)
	Power		Type	A	B	C	C*	C**	
	kW	HP							
ST 135-3	3	4	4"	520	NPT3" RP3"	138			9.9
ST 135-4	3.7	5	4"	577		138			10.8
ST 135-6	5.5	7.5	4"	691		138			12.6
ST 135-8	7.5	10	4"	805		138			14.3
ST 135-6	5.5	7.5	6"	705			141	144	13.5
ST 135-8	7.5	10	6"	819			141	144	15.2
ST 135-10	9.3	12.5	6"	933			141	144	17
ST 135-12	11	15	6"	1047			141	144	18.9
ST 135-14	13	17.5	6"	1161			141	144	20.7
ST 135-16	15	20	6"	1275			141	144	22.6
ST 135-20	18.5	25	6"	1555			141	144	27
ST 135-24	22	30	6"	1783			141	144	30.7
ST 135-28	26	35	6"	2063			141	144	35.1
ST 135-32	30	40	6"	2291			141	144	38.9

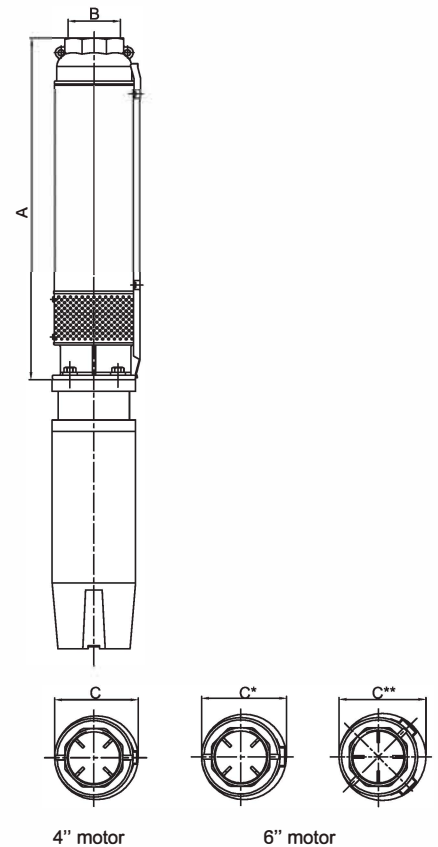

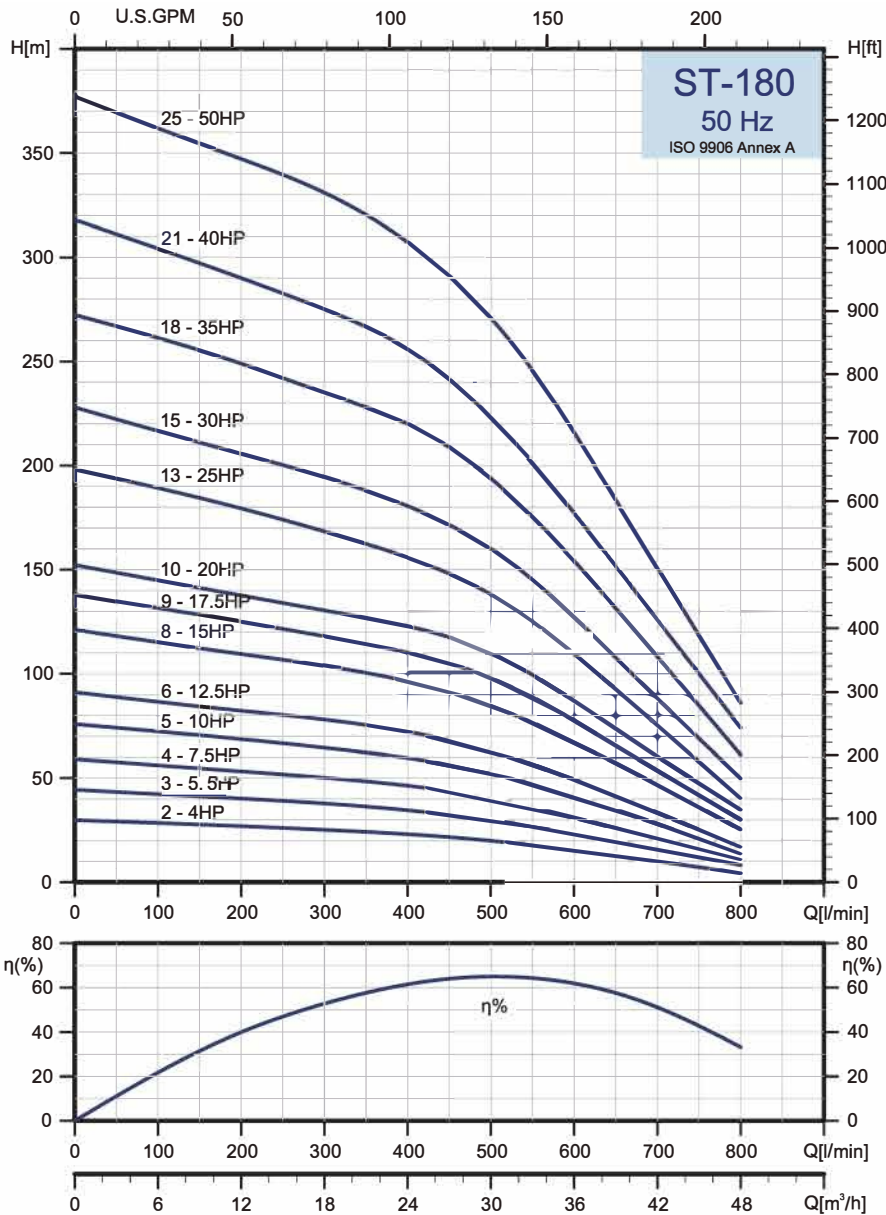

### Product data

Pump Type	HP	Q(m³/h)	H(m)	Hmax(m)
ST 180-02	4	34	17	30
ST 180-03	5.5	34	26	45
ST 180-04	7.5	34	35	59
ST 180-05	10	34	46	76
ST 180-06	12.5	34	55	92
ST 180-08	15	34	74	122
ST 180-09	17.5	34	86	138
ST 180-10	20	34	96	153
ST 180-13	25	34	121	199
ST 180-15	30	34	140	228
ST 180-18	35	34	169	273
ST 180-21	40	34	194	318
ST 180-25	50	34	237	378

### Dimensions and weights

Pump type	Motor			Dimensions(mm)					Weight(kg) Pump
	Power		Type	A	B	C	C*	C**	
	kW	HP							
ST 180-2	3	4	4"	469	NPT3" RP3"	138			8.9
ST 180-3	4	5.5	4"	529		138			9.9
ST 180-4	5.5	7.5	4"	589		138			10.7
ST 180-5	7.5	10	4"	649		138			11.8
ST 180-4	5.5	7.5	6"	603			141	144	11.6
ST 180-5	7.5	10	6"	663			141	144	12.6
ST 180-6	9.3	12.5	6"	723			141	144	13.6
ST 180-8	11	15	6"	843			141	144	15.5
ST 180-9	13	17.5	6"	903			141	144	16.5
ST 180-10	15	20	6"	963			141	144	17.4
ST 180-13	18.5	25	6"	1143			141	144	20.3
ST 180-15	22	30	6"	1263			141	144	22.2
ST 180-18	26	35	6"	1495			141	144	25.9
ST 180-21	30	40	6"	1675			141	144	28.6
ST 180-25	37	50	6"	1915			141	144	32.5

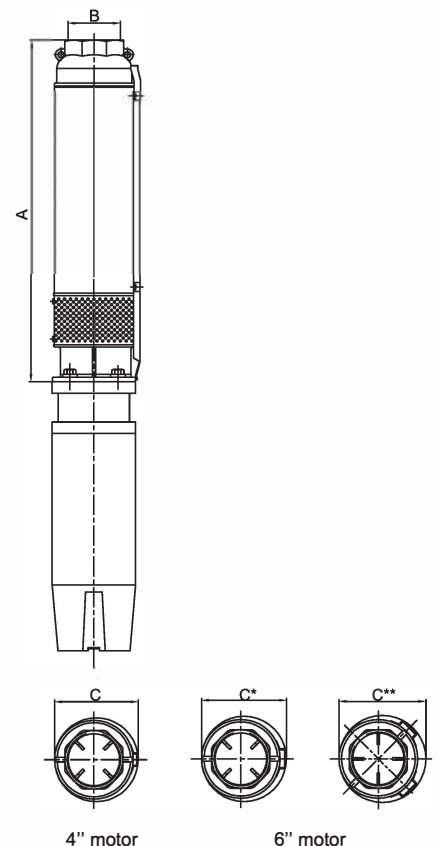

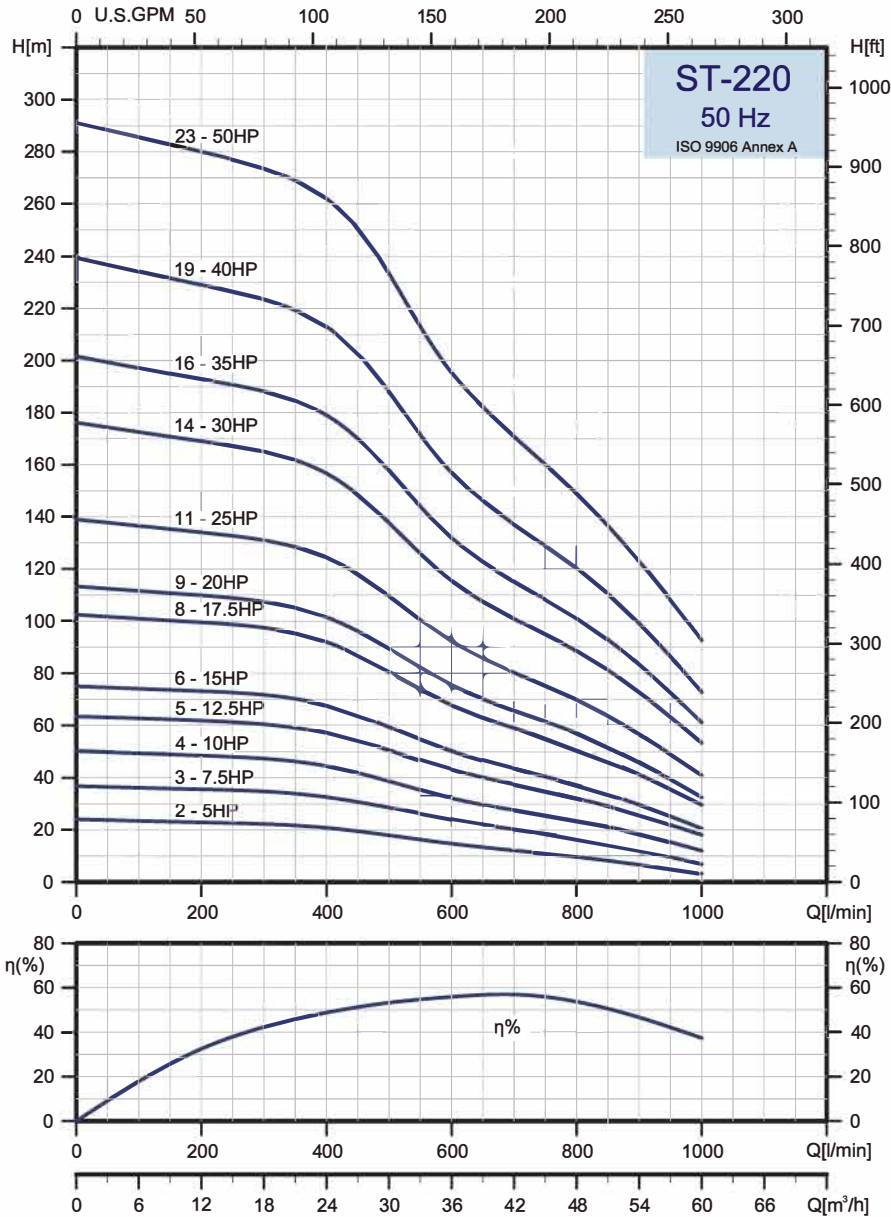

### Product data

Pump Type	HP	Q(m³/h)	H(m)	Hmax(m)
ST 220-02	5	42	13	25
ST 220-03	7.5	42	21	37
ST 220-04	10	42	28	51
ST 220-05	12.5	42	38	64
ST 220-06	15	42	44	75
ST 220-08	17.5	42	59	103
ST 220-09	20	42	66	114
ST 220-11	25	42	81	139
ST 220-14	30	42	101	177
ST 220-16	35	42	116	202
ST 220-19	40	42	138	240
ST 220-23	50	42	171	292

### Dimensions and weights

Pump type	Motor			Dimensions(mm)					Weight(kg)
	Power		Type	A	B	C	C'	C**	
	kW	HP							
ST 220-2	3.7	5	4"	469	NPT3" RP3"	138			8.9
ST 220-3	5.5	7.5	4"	529		138			9.9
ST 220-4	7.5	10	4"	589		138			10.8
ST 220-3	5.5	7.5	6"	543			141	144	10.7
ST 220-4	7.5	10	6"	603			141	144	11.7
ST 220-5	9.3	12.5	6"	663			141	144	12.6
ST 220-6	11	15	6"	723			141	144	13.6
ST 220-8	13	17.5	6"	843			141	144	15.5
ST 220-9	15	20	6"	903			141	144	16.5
ST 220-11	18.5	25	6"	1023			141	144	18.5
ST 220-14	22	30	6"	1203			141	144	21.5
ST 220-16	26	35	6"	1323			141	144	23.6
ST 220-19	30	40	6"	1555			141	144	27.6
ST 220-23	37	50	6"	1795			141	144	31.3

