



Submersible Grinder Pumps

Made in Taiwan



Catalogo 60 Hz

Model code

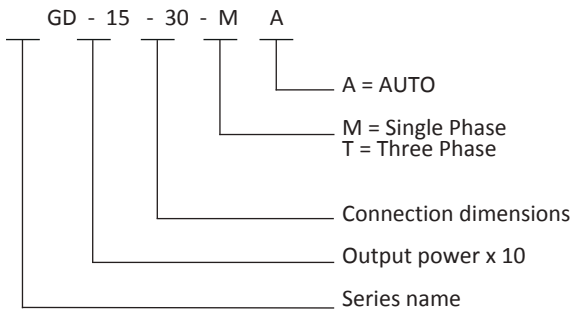

Application

- Waste water treatment
- Sewage water
- Drainage of wastewater from individual residences, apartment buildings, recreational developments, motels
- Transferring wastewater, Schools, federal, state and local parks
- To transfer various wastewater and sewage

Motor

- Motor Type: 2 POLE, dry type
- Frequency: 60Hz
- Insulation Class: E class (120°C)
- Nominal Speed: 3450 rpm

Pump

- Enclosure Protection Class: IP 68
- Protector: Thermal protection
- Insulation Class: E class (120°C)
- Bearing: Ball Type
- Mechanical seal: Dual. Mechanical Seal

Feature

- Robust construction
- Superior Heat Dissipation
- Vortex impeller design prevents clogging by cutting up articles
- Radial cutter and cutter ring SUS440C : corrosion resistant material, hardened to 55-60 Rockwell C
- Specific single phase design for starting torque, torque is five times stronger than General capacitor pump
- Horizontal casing with female thread can be fit the pipe directly
- Double mechanical seals Upper:CA/CE/NBR
Lower:SIC/SIC/NBR

Performance Curves

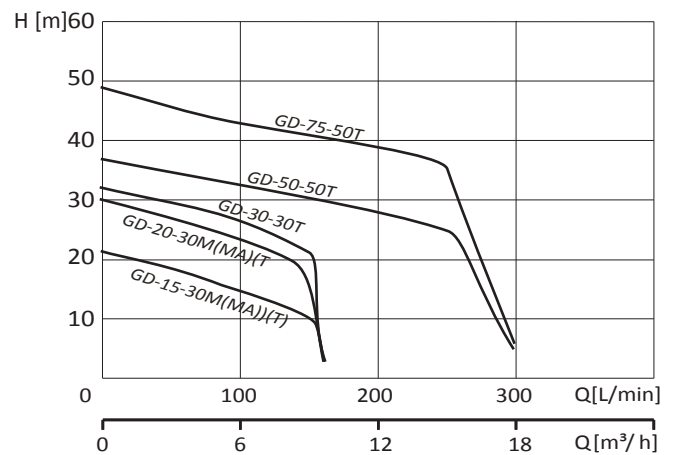

Operation Conditions

- Liquid Temperature: 0°C - 40°C (32-104°F)
- MAX.depth: 10M

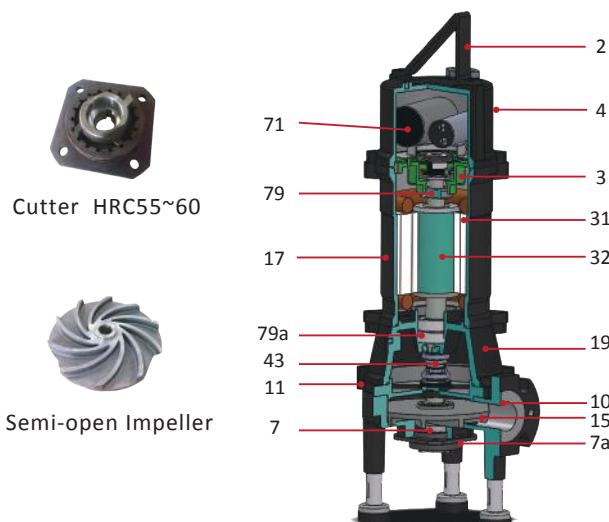

No.	Component	Material	
		1.5HP/2HP/3HP	5HP/7.5HP
2	Handle	SS 41	SS 41
3	Bracket	FC 200	FC 200
4	Upper Cover	FC 200	FC 200
7	Cutter	SUS 440C	SUS 440C
7a	Cutter Ring	SUS 440C	SUS 440C
10	Pump Casing	FC 200	FC 200
11	Seal Housing	FC 200	FC 200
15	Impeller	FC 200	FC 200
17	Motor Housing	FC 200	FC 200
19	Oil Chamber	FC 200	FC 200
31	Stator		
32	Shaft and Rotor	SUS 410	SUS 410
43	Mech. Seal	Upper:CA/CE/NBR Lower:SIC/SIC/NBR	Upper:CA/CE/NBR Lower:SIC/SIC/NBR
71	Capacitor	-	-
79	Upper Bearing	6203	6304
79a	Lower Bearing	6304	6305

Dimensions

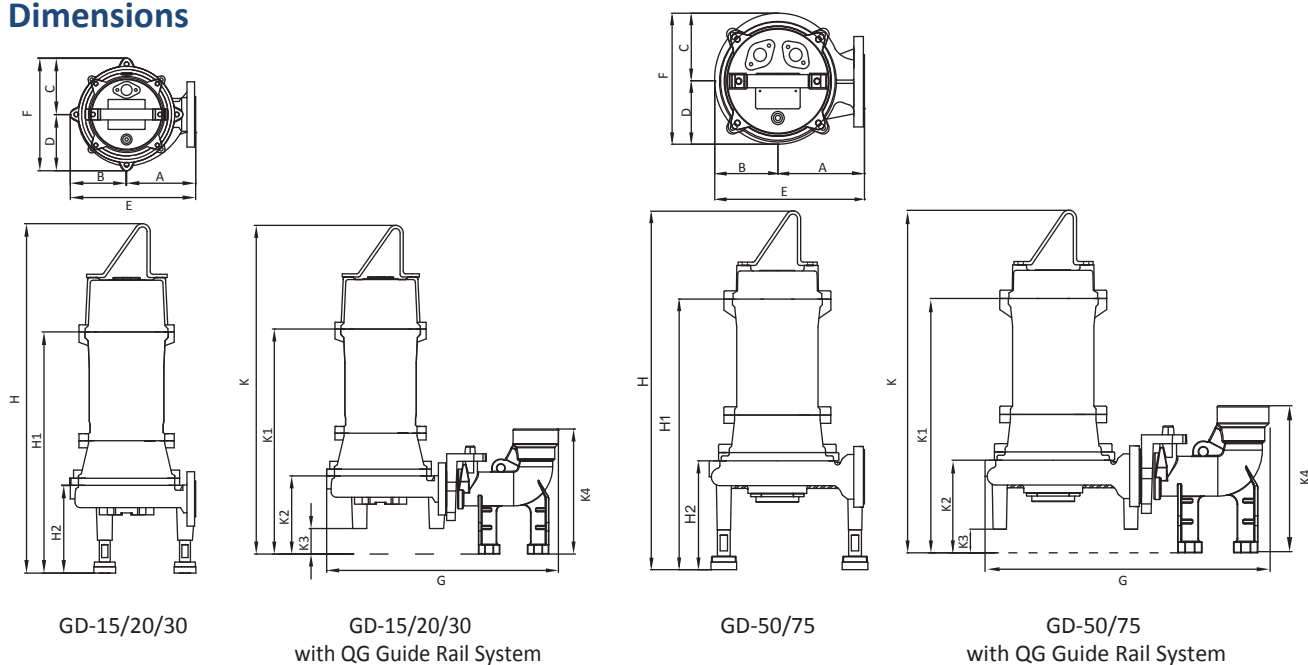

Model	Dimensions (mm)														
	A	B	C	D	E	F	G	H	H1	H2	K	K1	K2	K3	K4
GD-15-30	128	102	103	103	230	206	445	640	445	160	630	432	150	50	240
GD-20-30	128	102	103	103	230	206	445	640	445	160	630	432	150	50	240
GD-30-30	128	102	103	103	230	206	445	680	485	160	670	472	150	50	240
GD-50-50	164	119	125	114	283	239	500	669	509	186	637	477	154	29	240
GD-75-50	164	119	125	114	283	239	500	709	549	186	677	517	154	29	240

Specifications

Model	Phase	Voltage (V)	Power		Head (Pressure)		Flow (Capacity)		Connection	Cable	Weight
			HP	KW	Rated (M)	Max. (M)	Rated(L/min)	Max. (L/min)			
GD-15-30M	1 ϕ	230	1.5	1.1	15.5	21.5	90	160	1-1/4"	10	30
GD-15-30MA		230	1.5	1.1	15.5	21.5	90	160	1-1/4"	10	30.5
GD-20-30M		230	2	1.5	22	30	115	160	1-1/4"	10	32.8
GD-20-30MA		230	2	1.5	22	30	115	160	1-1/4"	10	33.3
GD-15-30T	3 ϕ	460	1.5	1.1	15.5	21.5	90	160	1-1/4"	10	30
GD-20-30T		460	2	1.5	22	30	115	160	1-1/4"	10	32.8
GD-30-30T		460	3	2.2	24	32	130	160	1-1/4"	10	35
GD-50-50T		460	5	3.7	26	37	240	300	2"	10	44
GD-75-50T		460	7.5	5.5	35	49	250	300	2"	10	49

- Model with "M" is single.
- Model with "T" is three.
- Model with "A" is AUTO.