



Silent Booster Pumps

Made in Taiwan



Catalogo 60 Hz.

The SSA series is an All-in-One self-priming silent booster pump, the compact design combined pressure tank, pressure switch, flow switch and full protection controller, moreover, the evolutionary flow channel and peripheral impeller design provide highly performance, by using this booster pump there is no more pump frequently On/Off, unstable water pressure and noise problems.

Model code

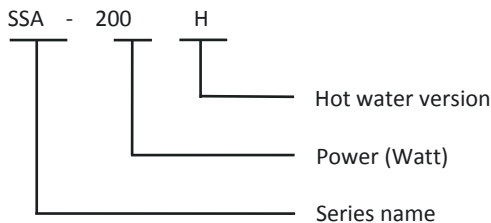

Applications

Water pressure
boosting Water
transferring Water
circulating

Motor

Motor Type: 2 Pole, totally enclosed fan-cooled
Frequency: 60Hz
Standard Voltages: 1Ø 110 or 220 V Insulation
Class: F class (155°C / 311°F) Enclosure
Protection Class: IP 54
Nominal Speed: 3450 RPM

Operation Conditions

Liquid Temperature: 2°C - 40°C
2°C - 90°C (H Type) Ambient
Temperature: 0°C - 40°C
Max System Pressure: SSA200/300/400 5kg/cm²
SSA600/800 7kg/cm²

Materials

Motor Frame: Aluminum
Pump Casing: Cast Iron
Shaft: SUS400 Series
Impeller: Brass
Mechanical Seal: Ceramic + Carbon + NBR (Standard Version)
Ceramic + Carbon + Viton (Hot water Version)

Features

- ※ Easy set-up, installation, and maintenance
- ※ The most silent operation in class
- ※ No more noise issue from pump short cycling
- ※ Best-in-class performance in the market
- ※ Higher efficiency for lower electricity bill
- ※ Robust construction for better reliability
- ※ Max. 8M self-priming suction lift
- ※ All-in-one compact design which integrates motor, pump, pressure tank, flow switch, pressure switch, and controller to provide the most stable water pressure
- ※ Anti-block system every 24 hours to prevent mechanical seal or impeller stick together
- ※ Controller wrote in dry-run protecting function to prevent pump or pipe damage (dry run without water over 2 minutes, the pump will automatically rest for 15 minutes and restart again, if above cycling happen accumulate 10 times, the rest time will become 90 minutes and restart afterward)
- ※ LED light signals to indicate 4 different operating statuses
 - Red light: Stand by
 - Green light: Pump on
 - Red flash: Over heat
 - Green flash: No water
- ※ Double thermal protection for motor
 - Pump-disconnect at 55°C, connect at 40°C
 - Motor-disconnect at 135 ± 5°C, connect at 86 ± 15°C

Performance Curves

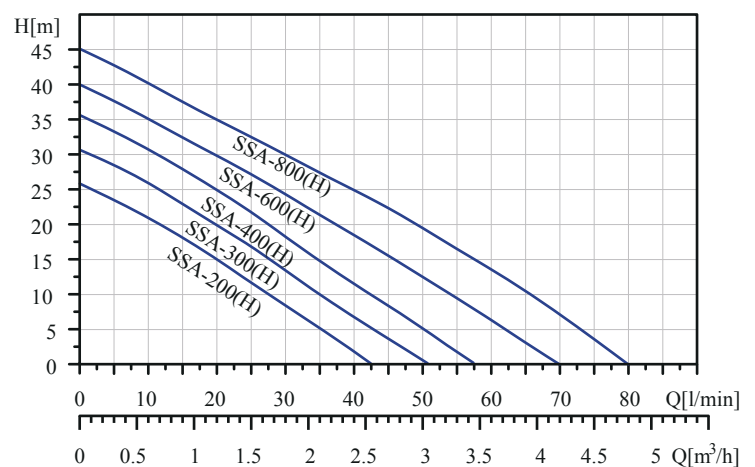

Dimension

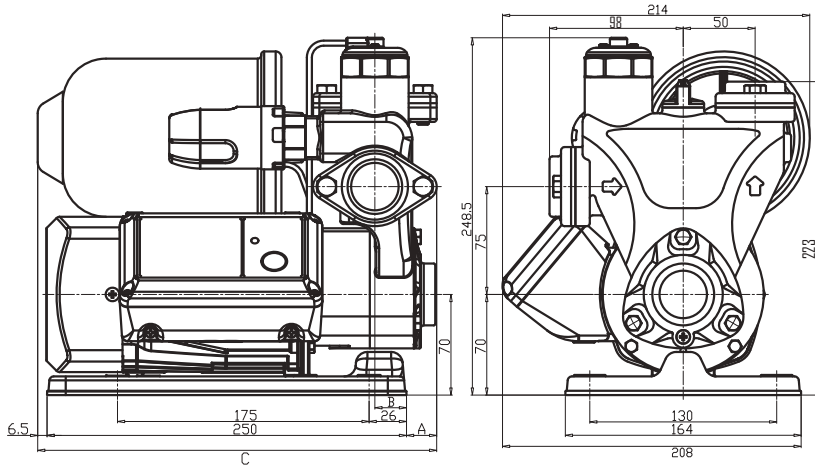

Model	A (mm)	B (mm)	C (mm)
SSA200	15	28	272
SSA300	17	26	274
SSA400	19	24	276

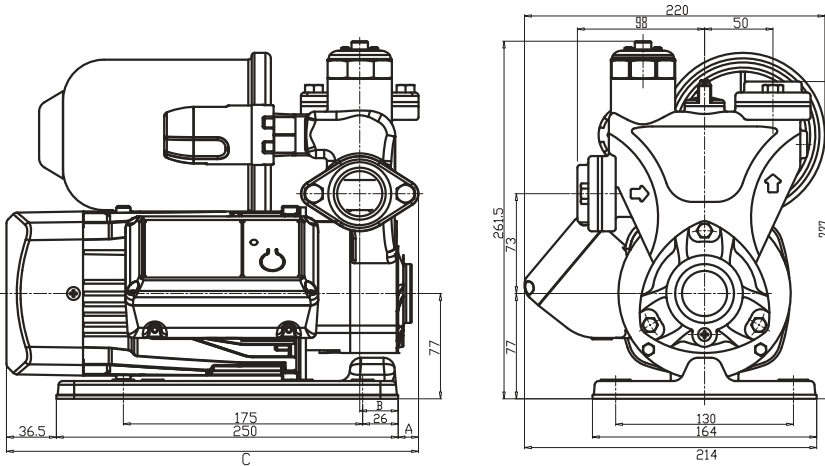

Model	A (mm)	B (mm)	C (mm)
SSA600	9	34	296
SSA800	11	33	297

Specifications

Model	Phase	Voltage	Power		Head		Flow		Ampere		Connection	Weight	Units/Pallet	Packing dimension	
			HP	Watt	Rated (M)	Max. (M)	Rated (L/min)	Max. (L/min)	Rated (A)	Max. (A)				L x W x H (cm)	
SSA-200	1Ø	110or220	0.25	200W	12.5	26	24	43	2.4/1.2	4.2/2.1	2	RP or NPT 1"	10	96	110 x 110 x 192
SSA-300		110or220	0.35	300W	13.5	31	30	51	2.8/1.4	5.6/2.8	3		10.5	96	
SSA-400		110or220	0.5	400W	14.5	36	35	57	3.4/1.7	6.6/3.3	4		11	96	
SSA-600		110or220	0.75	600W	15.5	40	45	70	6.2/3.1	10/5	5		13	78	110 x 110 x 192
SSA-800		110or220	1	800W	17.0	45	54	80	7.6/3.8	12/6	6		14.5	78	
SSA-200H	1Ø	110or220	0.25	200W	12.5	26	24	43	2.4/1.2	4.2/2.1	2	RP or NPT 1"	10	96	110 x 110 x 192
SSA-300H		110or220	0.35	300W	13.5	31	30	51	2.8/1.4	5.6/2.8	3		10.5	96	
SSA-400H		110or220	0.5	400W	14.5	36	35	57	3.4/1.7	6.6/3.3	4		11	96	
SSA-600H		110or220	0.75	600W	15.5	40	45	70	6.2/3.1	10/5	5		13	78	110 x 110 x 192
SSA-800H		110or220	1	800W	17	45	54	80	7.6/3.8	12/6	6		14.5	78	

• Models with "H" are hot water types.

Component / Material

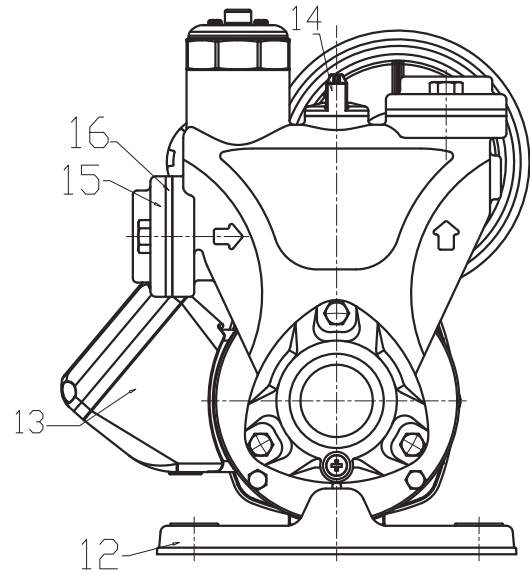
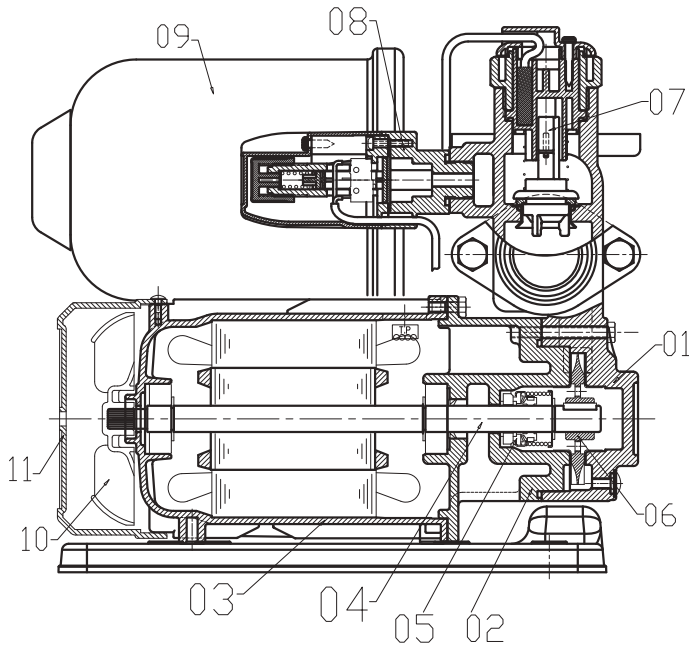

No.	Component	Material
01	Pump	FC200
02	Motor stool	FC200
03	Motor	ADC12
04	Shaft	stainless steel 400 series
05	Mechanical seal	Ceramic+Carbon+NBR(Standard) Ceramic+Carbon+Viton(Hot water)
06	Impeller	brass
07	Flow switch plus check vavle	Nylon+POM
08	Pressure switch	Nylon
09	Pressure tank	SPCC
10	Motor fan	PP
11	Fan cover	PP
12	Pump base	ABS
13	Wiring box	ABS
14	Filling plug	Nylon
15	Flange	FC200
16	Flange gasket	NBR

Key Components Description



A	Patented wind-collecting type centrifugal fan design provides great heat dissipation for motor and reduces wind noise
B	Patented intelligent pump controller highly integrates flow switch, pressure switch, and provides useful functions like dry-run protection, anti-block and delayed shutdown, (within 5 seconds) which help to achieve smother operation, more comfortable water shower and longer product life
C	Motor auto reset thermal protection for longer motor life
D	High rust resistant durable baked epoxy coating finish
E	Patented precise pressure switch design provides stable water pressure. The cut-in pressure setting can be slightly adjusted by hand
F	Patented balanced flow switch design provides stable water flow
G	In-let screen design prevents debris from getting into pump casing
H	Special impeller and flow channel design highly increase pump performance and self-priming ability under ultra-silent operation
I	Pump casing auto reset thermal protection to prevent dry running
J	Double stainless steel bushing design prevents impeller lock and wear