



50-60 Hz

Horizontal multistage
centrifugal pumps

Contents

CB, CBI

General data

2	Performance range 50 Hz, 60 Hz
3	Applications
3	Pump
3	Motor
4	Operating conditions
4	Type key, Mechanical seals
5	Material construction

Technical data

6	Performance curves CB, CBI 2, 4 50 Hz
8	Dimensions and weights CB, CBI 2, 4 50 Hz
9	Performance curves CB 8, 12 50 Hz
11	Dimensions and weights CB 8, 12 50 Hz
12	Performance curves CB, CBI 2, 4 60 Hz
14	Dimensions and weights CB,CBI 2, 4 60 Hz
15	Performance curves CB 8, 12 60 Hz
17	Dimensions and weights CB 8, 12 60 Hz

HBI, HBN

General data

18	Performance range 50 Hz, 60 Hz
19	Applications
19	Pump, Motor, Operating conditions
19	Liquids to be pumped
20	Type Key, Mechanical seals
20	Material construction

Technical data

21	Performance curves HBI, HBN 2, 4 50 Hz
23	Dimensions and weights HBI, HBN 2, 4 50 Hz
24	Performance curves HBI, HBN 8, 12 50 Hz
26	Dimensions and weights HBI, HBN 8, 12 50 Hz
27	Performance curves HBI,HBN 2, 4 60 Hz
29	Dimensions and weights HBI,HBN 2, 4 60 Hz
30	Performance curves HBI,HBN 8, 12 60 Hz
32	Dimensions and weights HBI,HBN 8, 12 60 Hz

Performance range, 50Hz

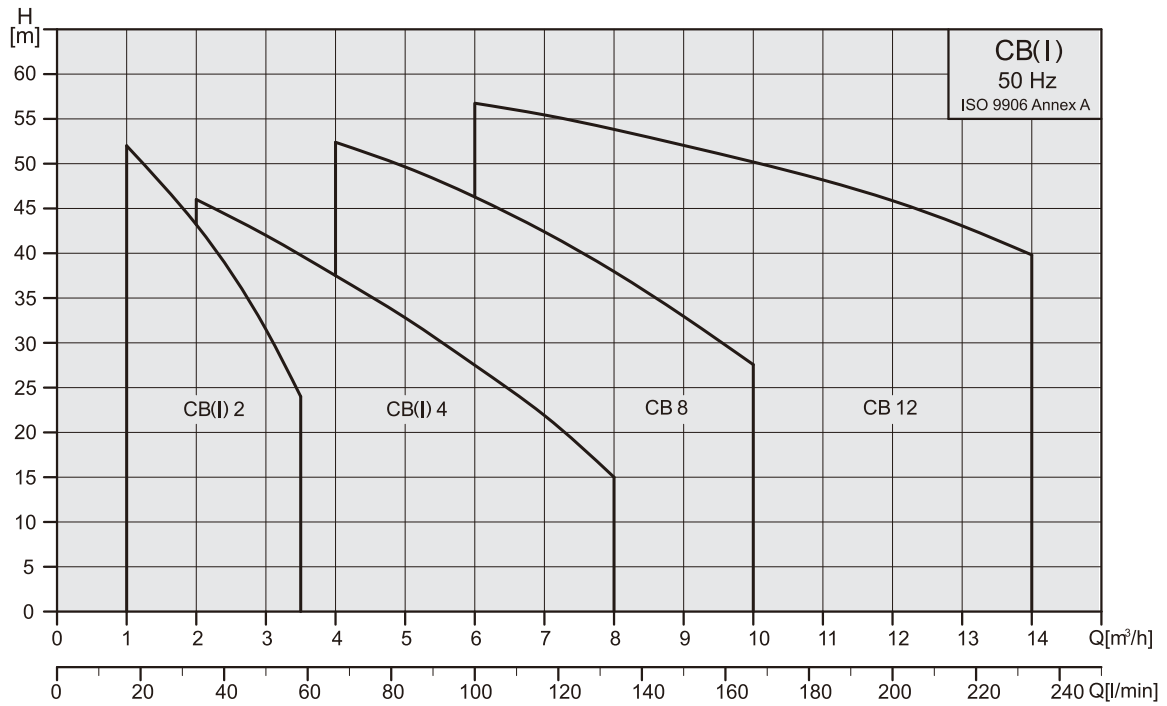

Performance range, 60Hz

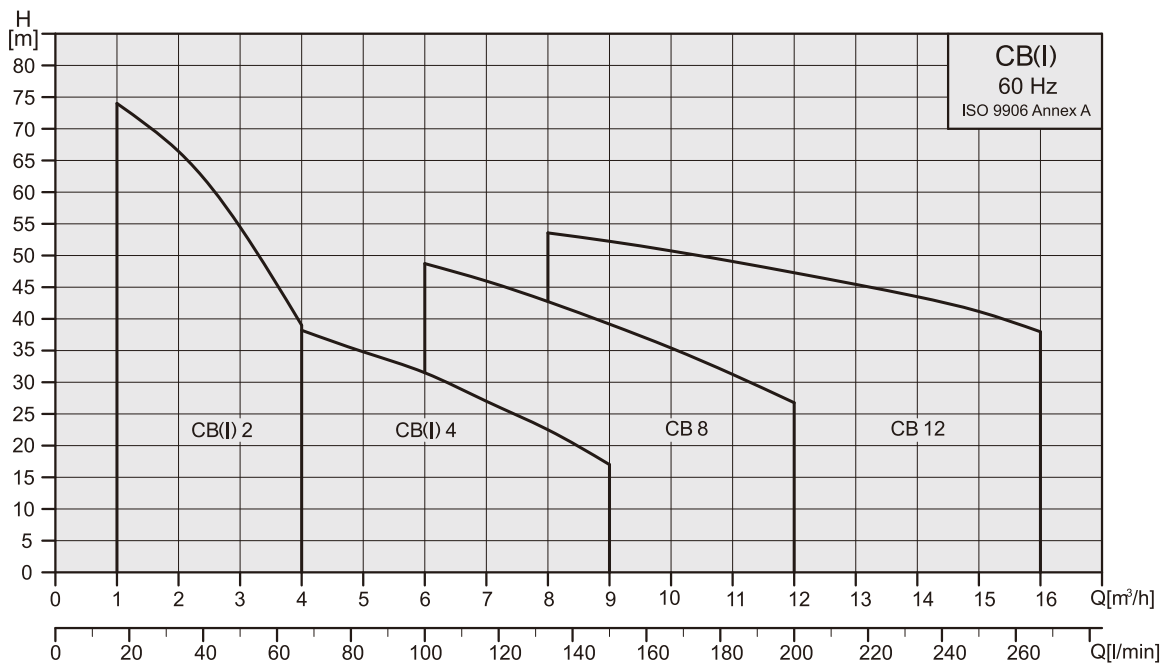

Applications

- *Domestic
- *Liquid transfer and circulation of liquids within light industry and farming
- *Pressure boosting
- *Air-conditioning systems
- *Cooling systems or cooling machine
- *Specialized OEM equipment

Pump

The CB and CBI series are non-self priming, horizontal multistage centrifugal pumps. Pump is coupled with motor at the same shaft and mounted on a base-plate. The friendly design makes the pump suitable for installation in the small domestic or industrial water supply systems. The pump is fitted with a mechanical seal and through-going pump-motor shaft.

CB: The discharge and suction chamber are made of cast iron. The other parts of pump in contact with the liquid are made of stainless steel.

CBI: All parts of pump in contact with the liquid are made of stainless steel.

EPDM or Viton O-rings are available as standard.

Pipe connections:

Connections	CB, CBI 2	CB, CBI 4	CB8	CB12
Suction port	Rp 1	Rp 1 1/4	Rp 1 1/2	Rp 1 1/2
Discharge port	Rp 1	Rp 1	Rp 1 1/4	Rp 1 1/2
Drain hole, priming hole	Rc 3/8	Rc 3/8	Rp 1/2	Rp 1/2

Motor

The pump is fitted with a totally enclosed, fan-cooled, squirrel-cage motor.

Rated speed: 2850rpm(50Hz), 3450rpm(60Hz)

Enclosure class: IP 54

Insulation class: F

Standard voltages:

50HZ 1Ø

0.5HP~3.0HP 220-240V

60HZ 1Ø

0.5HP~1.0HP 110/220V

1.5HP~3.0HP 220-240V

50HZ 3Ø

0.5HP~4.0HP 220-240V/380-415V

60HZ 3Ø

0.5HP~1.5HP 220-255V/380-440V

2.0HP~4.0HP 220-277V/380-480V

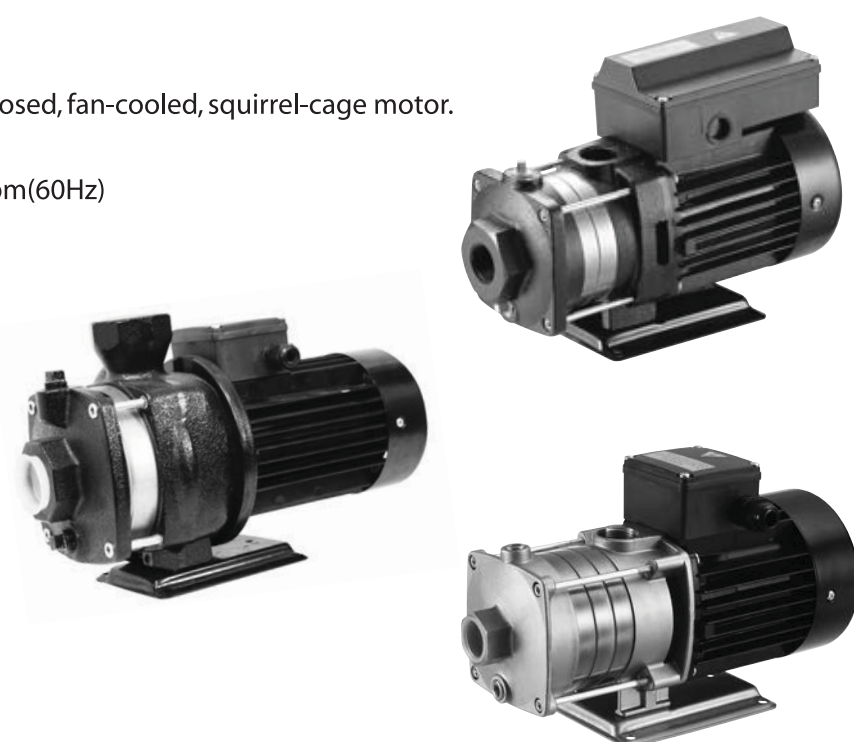

Operating conditions

Liquid: Clean liquid without solid particles.

Liquid temperature range: 0°C ~ +90°C.

Maximum ambient temperature: +50°C.

The maximum operating pressure depends on the temperature of the pumped liquid, see table:

Max. operating pressure	10 kg/cm ²	6 kg/cm ²
CB(1)2, CB(1)4	0°C to + 40°C	+41°C to + 90°C
CB 8, CB12	0°C to + 55°C	+56°C to + 90°C

Min. inlet pressure: According to the NPSH curve + a safety margin of 0.5m.

Max. inlet pressure: Limited by the max. operating pressure.

Type key

Example CB(1) 4 - 30 - CQBE
 Pump type Nominal flow rate [m³/h] Number of stages x 10 Mechanical Seals

Mechanical seals

List of Materials	
Q : Silicon carbide	E : EPDM
U : Tungsten carbide	V : Viton
B : Carbon	C : Seal Type
H : Seal Type	

Mechanical Seals	CB, CBI 2/4	CB 8,12
CQB	●	●
CQQ	Optional	Optional
HUU	Optional	Optional
O-rings		
E	●	●
V	●	●

● Standard

Material construction

CB(I) 2,4

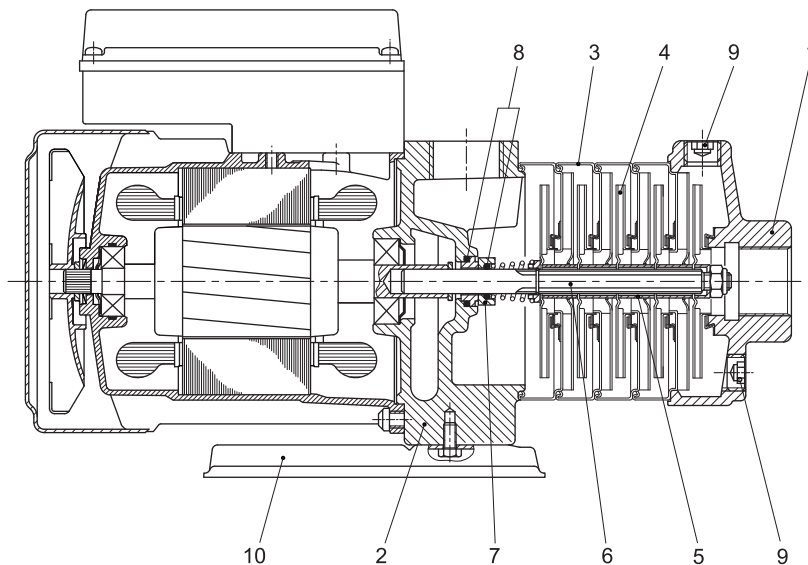

CB 8,12

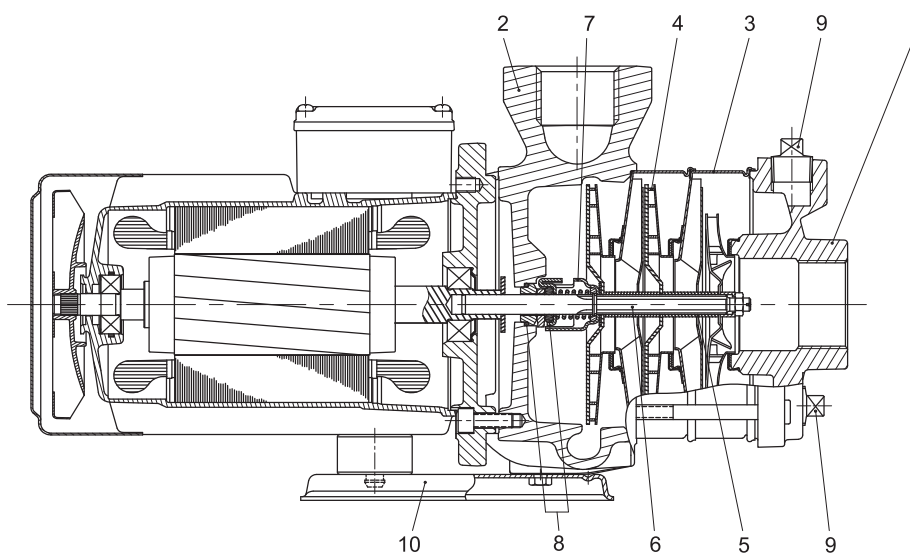

Materials

Pos.	Description	Materials	
		CB	CBI
1	Suction chamber	Cast iron	SS304
2	Pump head	Cast iron	SS304
3	Intermediate chamber	SS304	SS304
4	Impeller	SS304	SS304
5	Spacing pipe	SS304	SS304
6	Shaft	SS431	SS431
7	Mechanical seal	Silicon carbide / Carbon	Silicon carbide / Carbon
8	O-ring	EPDM or Viton	EPDM or Viton
9	Drain and priming plug	Steel	SS304
10	Base plate	Steel	SS304

Performance curves 50Hz

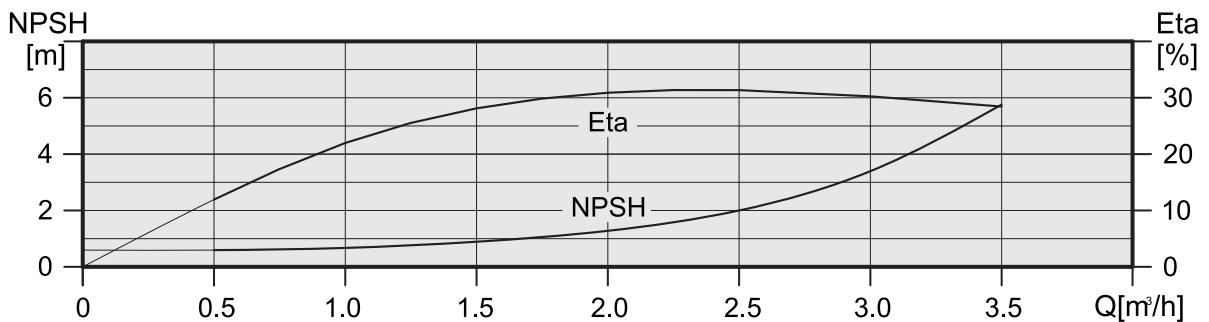
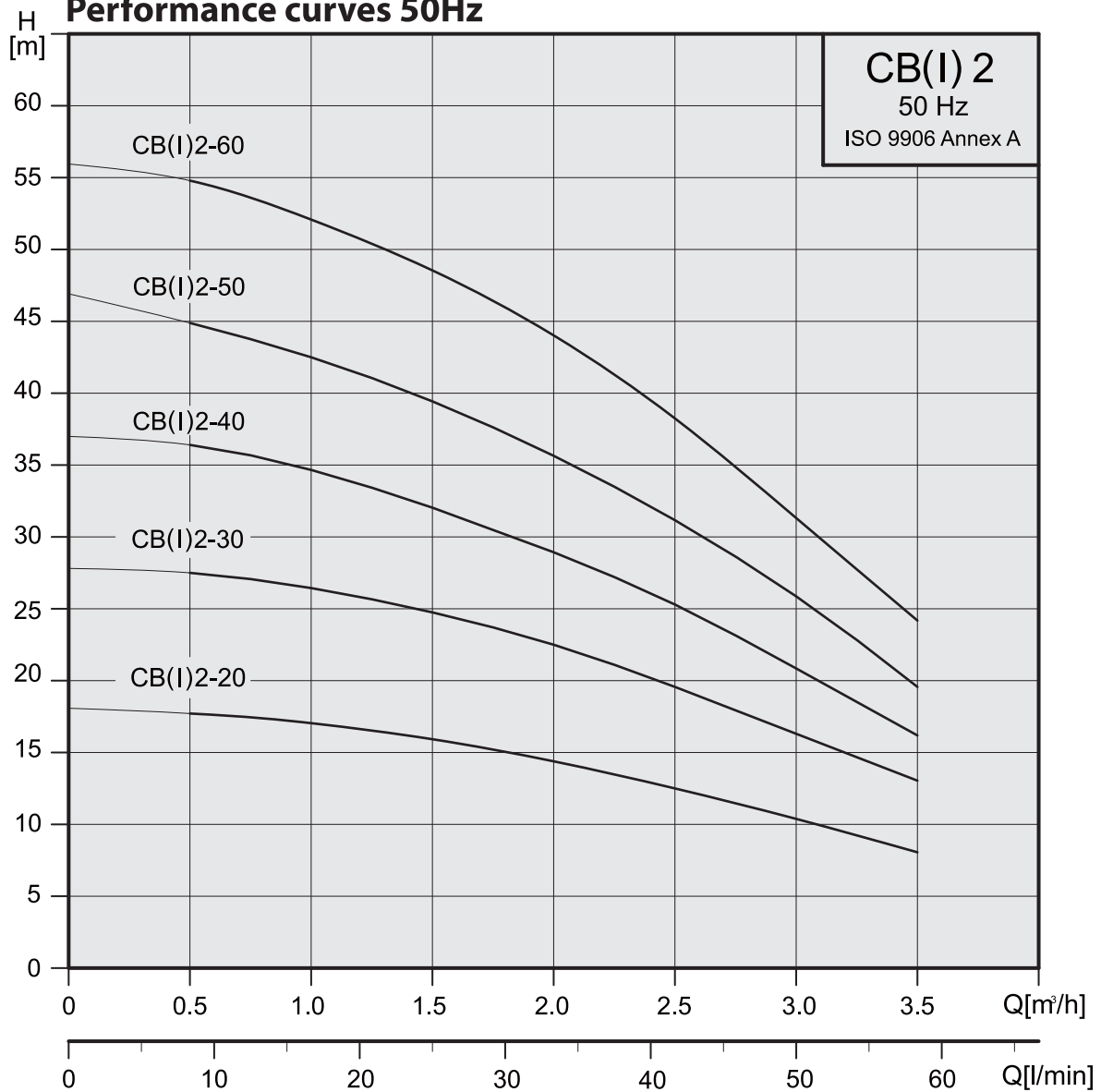

Electrical data, 2850 min⁻¹

pump type	1 x 220-240 V		3 x 220-240 Δ/380-415 Y V	
	P ₁ [W]	I _{1/1} [A]	P ₁ [W]	I _{1/1} [A]
CB/CBI 2-20	380	1.7-2.0	430	2.2-2.6 / 1.3-1.5
CB/CBI 2-30	470	2.1-2.2	530	2.2-2.5 / 1.3-1.45
CB/CBI 2-40	620	2.7-2.8	660	2.4-2.8 / 1.4-1.6
CB/CBI 2-50	720	3.2-3.1	770	2.5-2.9 / 1.45-1.7
CB/CBI 2-60	830	3.7-3.6	860	2.9-3.3 / 1.7-1.9

Performance curves 50Hz

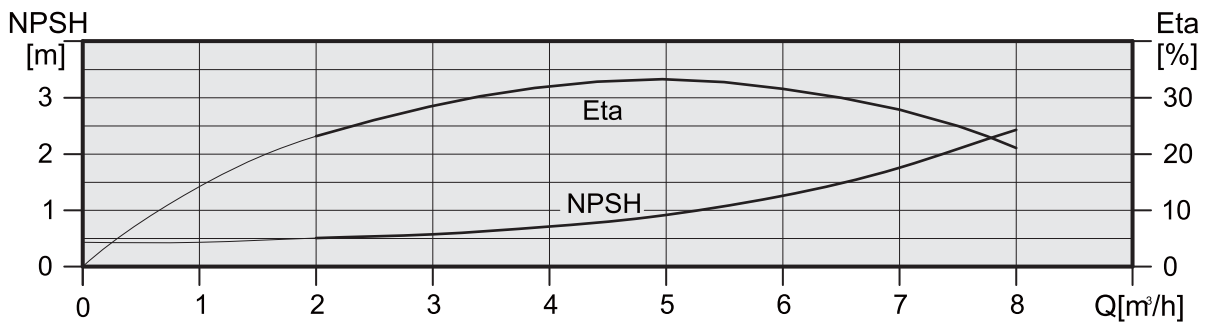
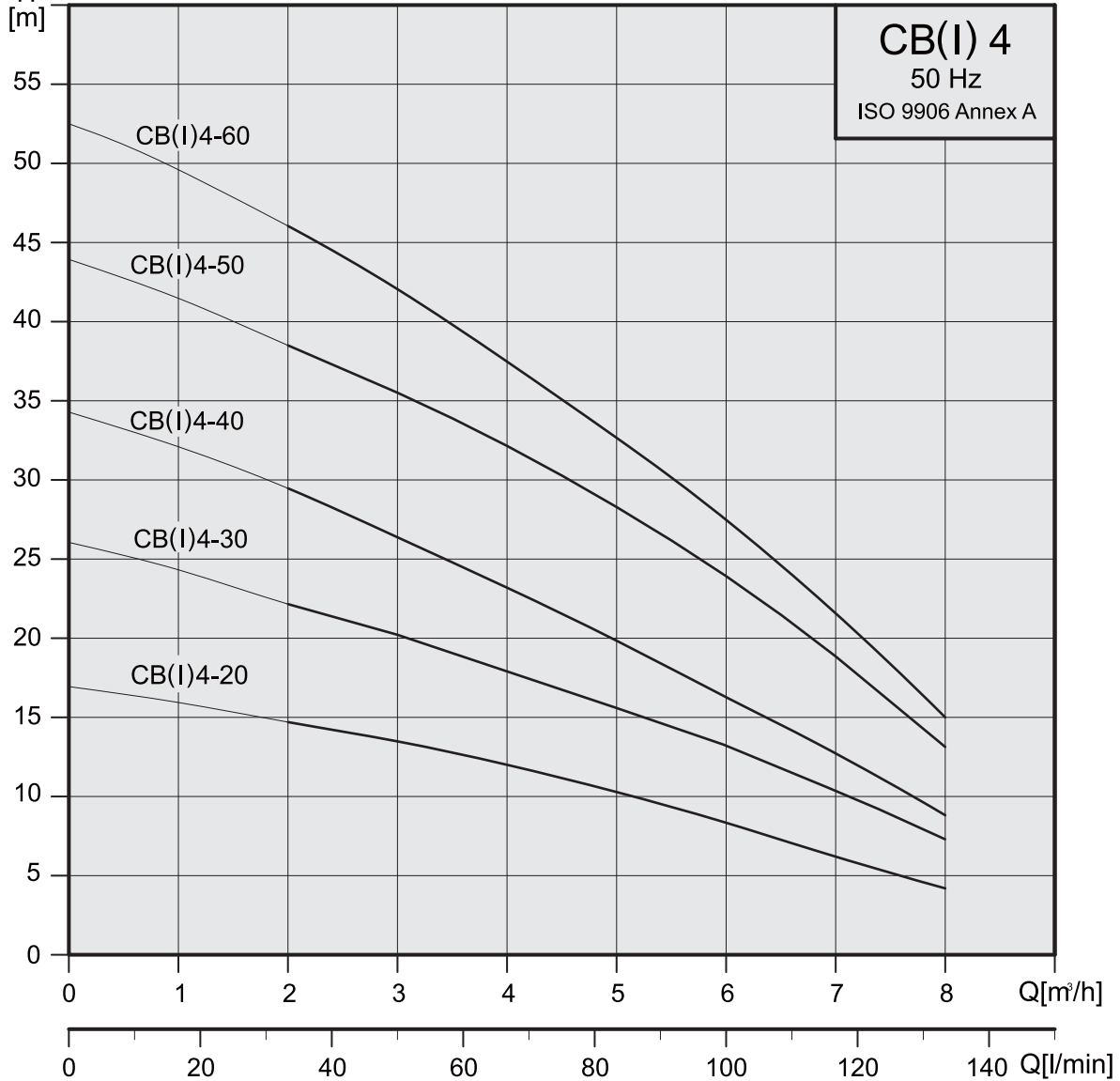

Electrical data, 2850 min⁻¹

pump type	1 x 220-240 V		3 x 220-240 Δ / 380-415 Y V	
	P ₁ [W]	I ₁ [A]	P ₁ [W]	I ₁ [A]
CB/CBI 4-20	560	2.6-2.5	610	2.4-2.9 / 1.4-1.7
CB/CBI 4-30	770	3.6-3.5	790	2.5-2.9 / 1.5-1.7
CB/CBI 4-40	960	4.4-4.1	1010	3.1-3.3 / 1.8-1.9
CB/CBI 4-50	1160	5.3-5.0	1240	4.2-4.5 / 2.4-2.6
CB/CBI 4-60	1430	6.7-6.4	1460	5.1-5.5 / 2.9-3.2

Dimensions and weights 50 Hz

CB-2, CB-4

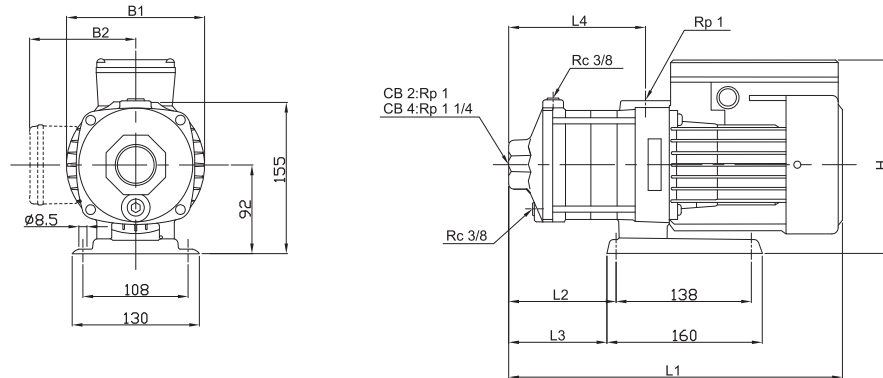

pump type	mm										Kg	
	L1	L2	L3	L4	B1	B2		H		1phase	3phase	
						1phase	3phase	1phase	3phase			
CB 2-20	309	75	63	101	141	127	112	228	206	10.3	10.0	
CB 2-30	327	93	81	119	141	127	112	228	206	10.5	10.3	
CB 2-40	345	111	99	137	141	127	112	228	206	10.8	10.5	
CB 2-50	363	129	117	155	141	127	112	228	206	11.6	11.2	
CB 2-60	381	147	135	173	141	127	112	228	206	11.8	11.5	
CB 4-20	318	84	72	110	141	127	112	228	206	10.4	10.1	
CB 4-30	344	111	99	137	141	127	112	228	206	10.8	10.5	
CB 4-40	372	138	126	164	141	127	112	228	206	11.6	11.2	
CB 4-50	438	165	153	191	141	127	112	228	206	13.4	13.1	
CB 4-60	465	192	180	218	141	127	112	228	206	14.8	14.5	

CBI-2, CBI-4

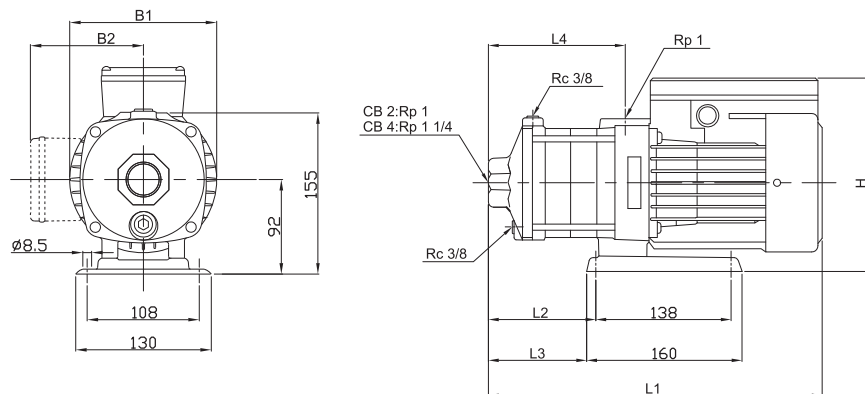

pump type	mm										Kg	
	L1	L2	L3	L4	B1	B2		H		1phase	3phase	
						1phase	3phase	1phase	3phase			
CBI 2-20	309	75	63	101	141	127	112	228	206	9.1	8.8	
CBI 2-30	327	93	81	119	141	127	112	228	206	9.4	9.1	
CBI 2-40	345	111	99	137	141	127	112	228	206	9.6	9.4	
CBI 2-50	363	129	117	155	141	127	112	228	206	10.4	10.1	
CBI 2-60	381	147	135	173	141	127	112	228	206	10.7	10.3	
CBI 4-20	318	84	72	110	141	127	112	228	206	9.2	9.0	
CBI 4-30	344	111	99	137	141	127	112	228	206	9.6	9.3	
CBI 4-40	372	138	126	164	141	127	112	228	206	10.4	10.1	
CBI 4-50	438	165	153	191	141	127	112	228	206	11.3	12.0	
CBI 4-60	465	192	180	218	141	127	112	228	206	13.6	13.4	

Performance curves 50Hz

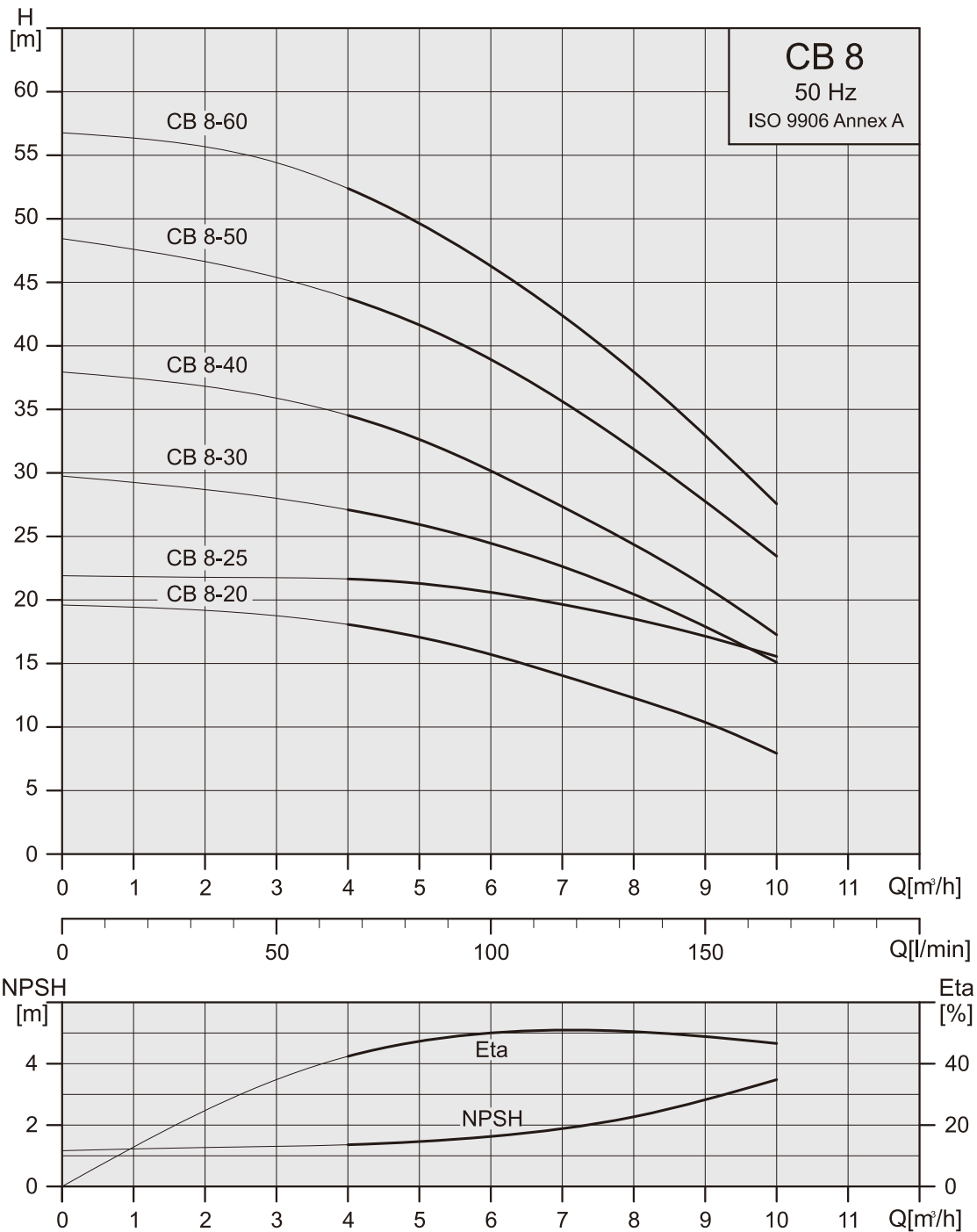

Electrical data, 2850min⁻¹

pump type	1x220-240 V		3x220-240/380-415 V	
	P ₁ [W]	I _{1/n} [A]	P ₁ [W]	I _{1/n} [A]
CB 8-20	760	3.3-3.2	810	2.9-3.3 / 1.7-1.9
CB 8-25	-	-	1060	3.5-3.8 / 2.0-2.2
CB 8-30	1130	5.2-5.0	1260	4.3-4.8 / 2.5-2.8
CB 8-40	1390	6.3-6.1	1520	5.7-6.3 / 3.3-3.7
CB 8-50	1940	8.2-8.1	1860	5.7-6.3 / 3.4-3.7
CB 8-60	2090	9.0-8.8	2110	6.5-7.0 / 3.8-4.1

Performance curves 50Hz

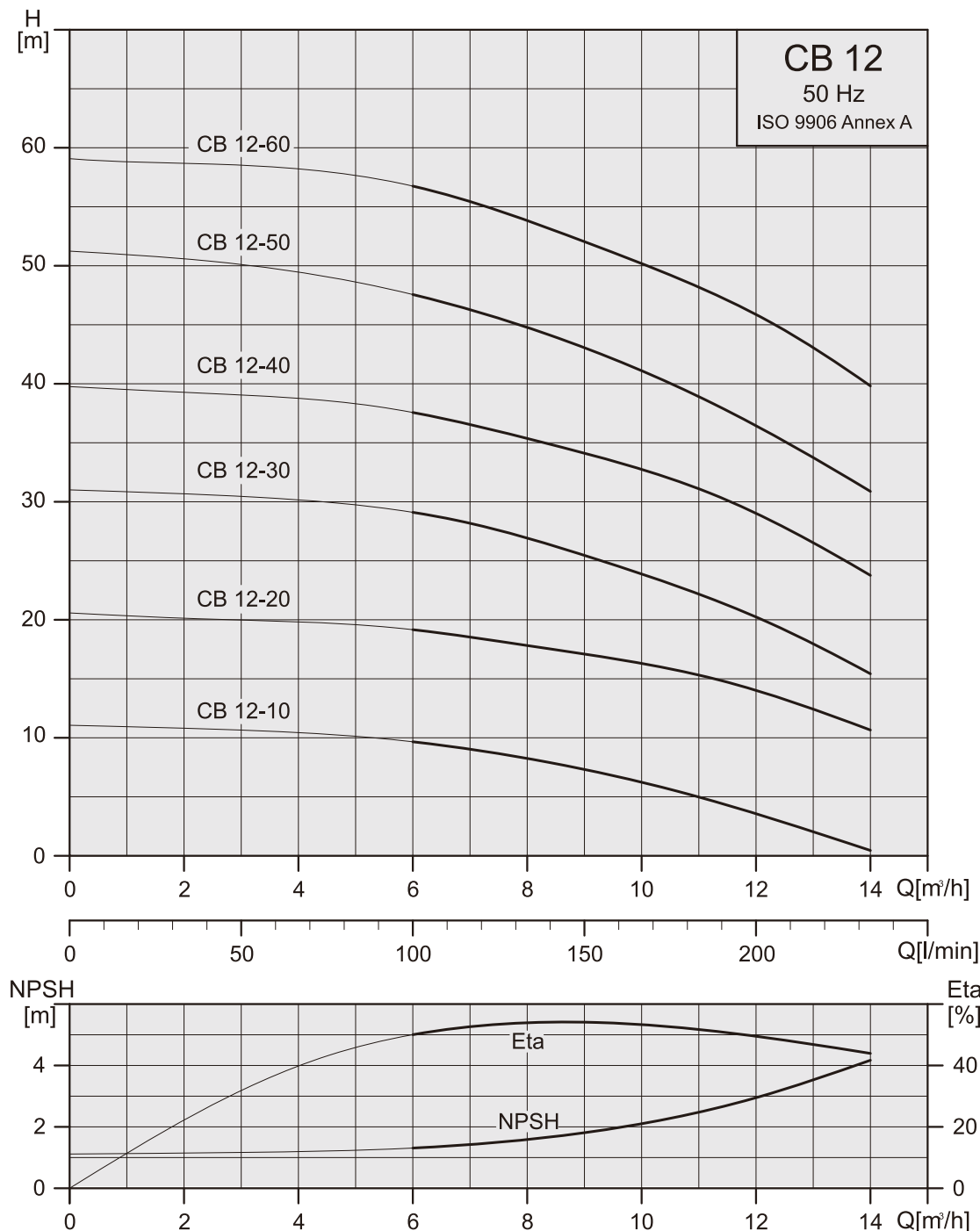

Electrical data, 2850min⁻¹

pump type	1x220-240 V		3x220-240/380-415 V	
	P ₁ [W]	I _{1/n} [A]	P ₁ [W]	I _{1/n} [A]
CB 12-10	-	-	590	2.8-3.1 / 1.6-1.8
CB 12-20	1160	5.3-5.1	1170	3.8-4.0 / 2.2-2.3
CB 12-30	1680	7.8-7.4	1690	5.7-6.5 / 3.3-3.8
CB 12-40	2400	11.0-10.6	2350	7.3-7.6 / 4.2-4.4
CB 12-50	2910	12.7-12.2	2820	8.8-9.0 / 5.1-5.2
CB 12-60	-	-	3320	10.6-11.4 / 6.1-6.6

Dimensions and weights 50 Hz

CB-8

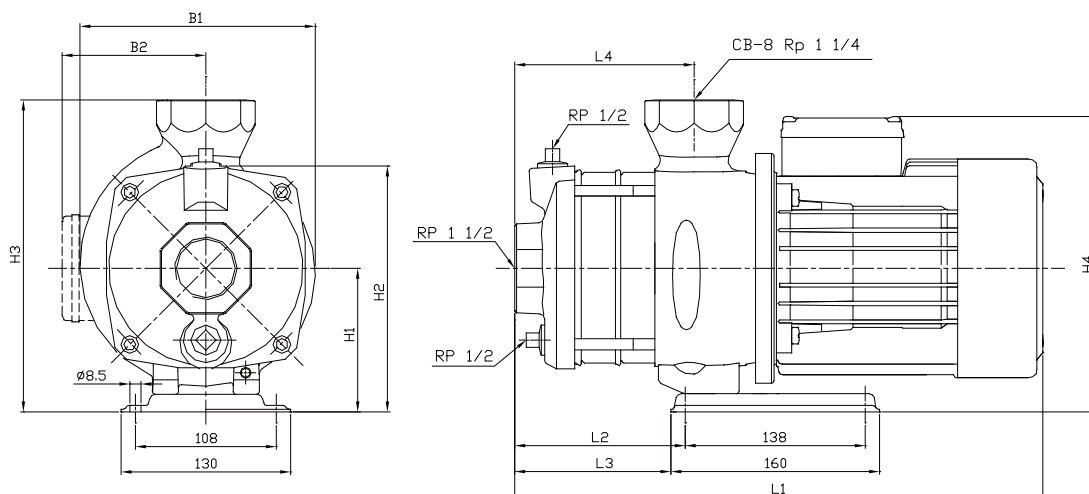

pump type	mm														Kg	
	L1		L2	L3	L4	B1		B2		H1	H2	H3	H4		1phase	3phase
	1phase	3phase				1phase	3phase	1phase	3phase				1phase	3phase		
CB 8-20	320	320	54	42	78	181	181	136	116	112	190	240	248	228	17.2	17
CB 8-25	-	390	84	72	108	-	181	-	116	112	190	240	-	228	-	19.1
CB 8-30	390	390	84	72	108	181	181	136	116	112	190	240	248	228	19.5	19.2
CB 8-40	390	390	84	72	108	181	181	136	116	112	190	240	248	228	20.72	20.5
CB 8-50	478	420	132	120	138	185	181	156	116	112	190	240	268	228	27.9	21.4
CB 8-60	478	478	132	120	138	185	185	156	141	112	190	240	268	253	28.1	27

CB-12

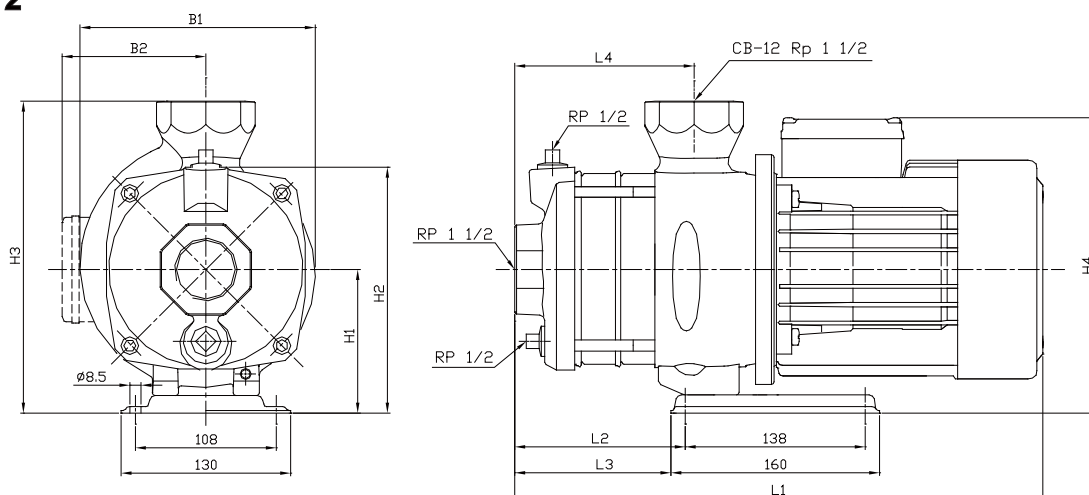

pump type	mm														Kg	
	L1		L2	L3	L4	B1		B2		H1	H2	H3	H4		1phase	3phase
	1phase	3phase				1phase	3phase	1phase	3phase				1phase	3phase		
CB 12-10	-	320	54	42	78	-	181	-	116	112	190	240	-	228	-	17.85
CB 12-20	360	360	54	42	78	181	181	136	116	112	190	240	248	228	18.35	18.15
CB 12-30	390	390	84	72	108	181	181	136	116	112	190	240	248	228	20.62	20.4
CB 12-40	448	448	102	90	108	185	185	156	141	112	190	240	268	253	27.05	26.05
CB 12-50	478	450	132	120	138	185	185	156	141	112	190	240	268	253	29.22	29.3
CB 12-60	-	503	132	120	138	-	196	-	147	125	203	253	-	272	-	34.58

Performance curves 60 Hz

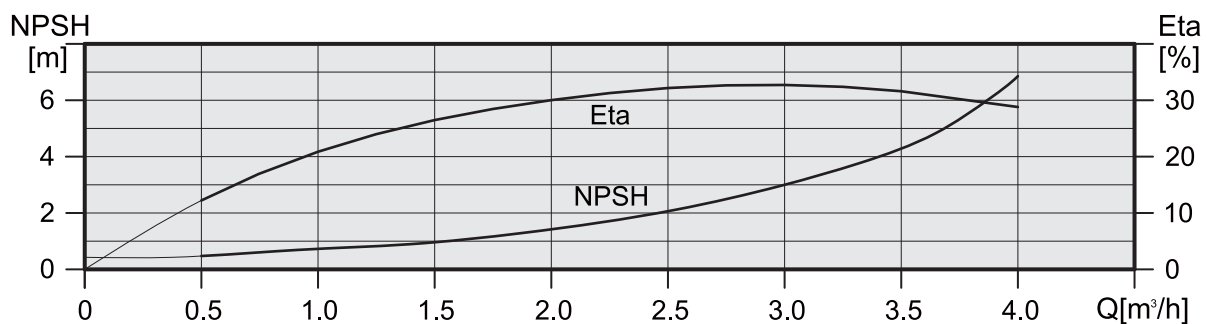
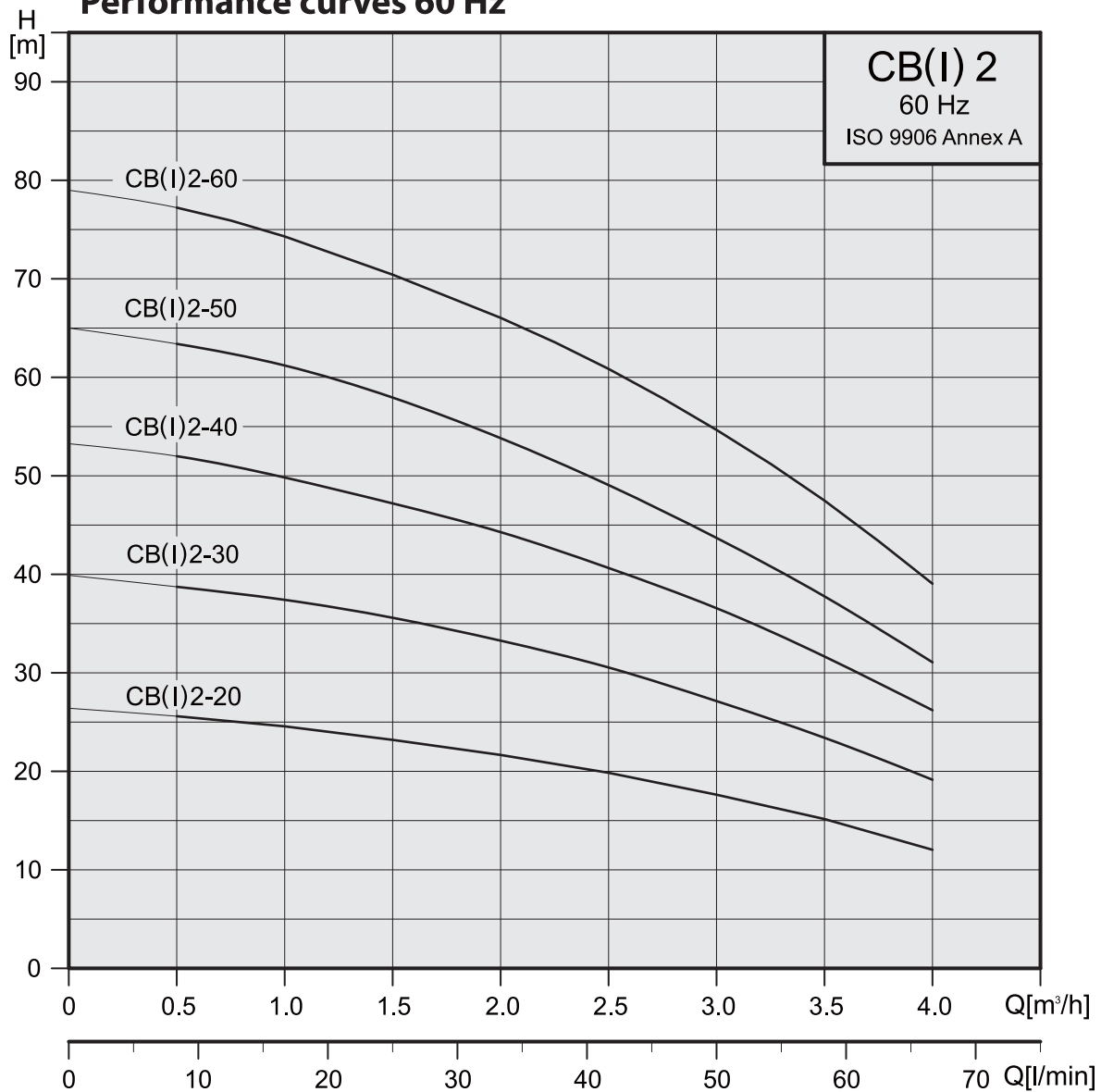

Electrical data, 3450 min⁻¹

pump type	1 x 110/220 V		3x220-255/380-440 V	
	P ₁ [W]	I _{1/n} [A]	P ₁ [W]	I _{1/n} [A]
CB/CBI 2-20	570	6.3-3.2	550	1.8-1.9 / 1.0-1.1
CB/CBI 2-30	780	7.9-4.1	680	3.5-3.3 / 2.0-1.9
CB/CBI 2-40	870	8.8-4.4	950	3.1-3.2 / 1.8-1.9
CB/CBI 2-50	1190	11.7-5.9	1160	3.7-3.8 / 2.1-2.2
CB/CBI 2-60	1410	13.7-6.9	1280	3.7-3.8 / 6.4-6.6

Performance curves 60Hz

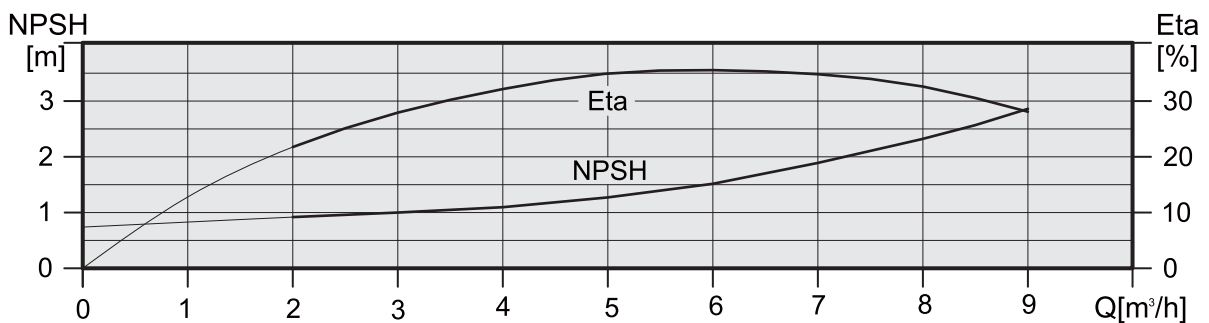
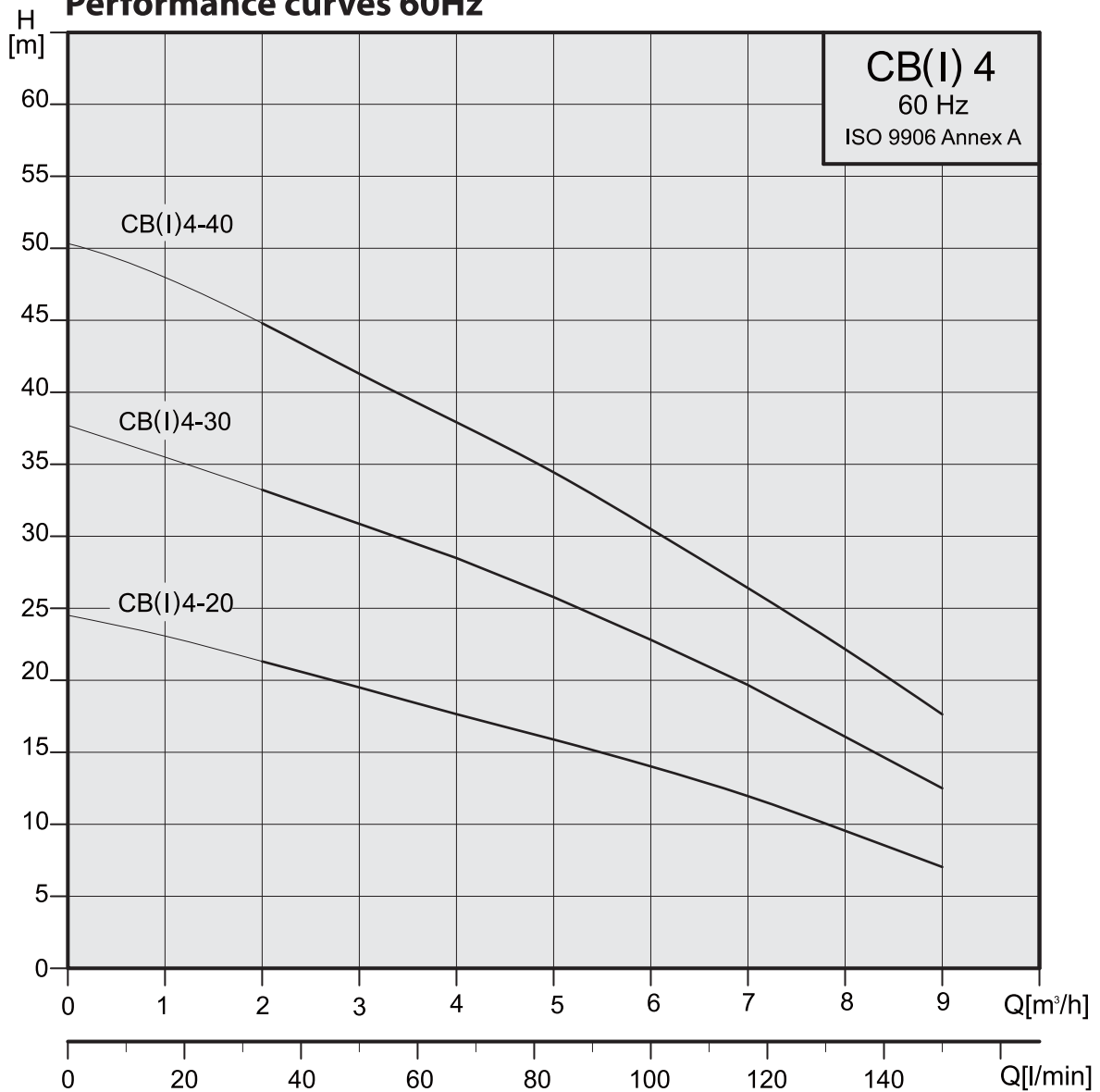

Electrical data, 3450 min⁻¹

pump type	1 x 110/220 V		3x220-255/380-440 V	
	P ₁ [W]	I _{1/1} [A]	P ₁ [W]	I _{1/1} [A]
CB/CBI 4-20	950	9.5 / 4.7	890	2.85-3.0 / 1.65-1.8
CB/CBI 4-30	1310	2.5 / 6.2	1250	3.9-4.0 / 2.3-2.4
CB/CBI 4-40	1700	8.3(220V)	1630	5.1-5.3 / 2.9- 3.1

Dimensions and weights 60 Hz

CB-2, CB-4

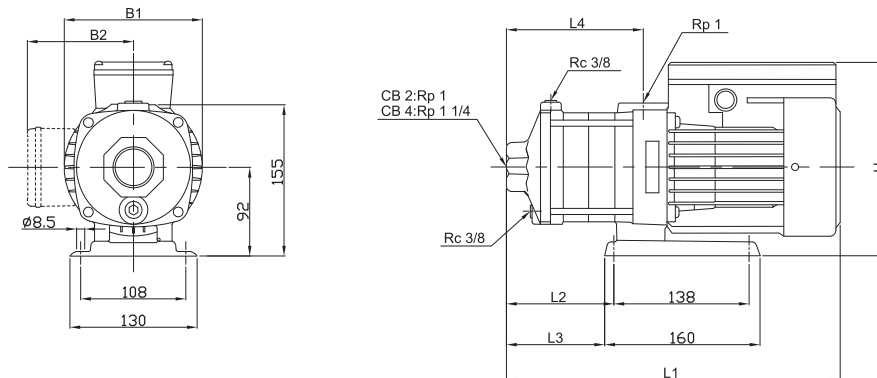

pump type	mm										Kg	
	L1	L2	L3	L4	B1	B2		H		1phase	3phase	
						1phase	3phase	1phase	3phase			
CB 2-20	309	75	63	101	141	127	112	228	206	10.3	10.0	
CB 2-30	327	93	81	119	141	127	112	228	206	11.1	10.8	
CB 2-40	345	111	99	137	141	127	112	228	206	11.3	11.1	
CB 2-50	403	129	117	155	141	127	112	228	206	13	12.4	
CB 2-60	421	147	135	173	141	127	112	228	206	13.2	12.7	
CB 4-20	318	84	72	110	141	127	112	228	206	12.2	10.7	
CB 4-30	384	111	99	137	141	127	112	228	206	12.7	12.3	
CB 4-40	412	138	126	164	141	127	112	228	206	14	13.7	

CBI-2, CBI-4

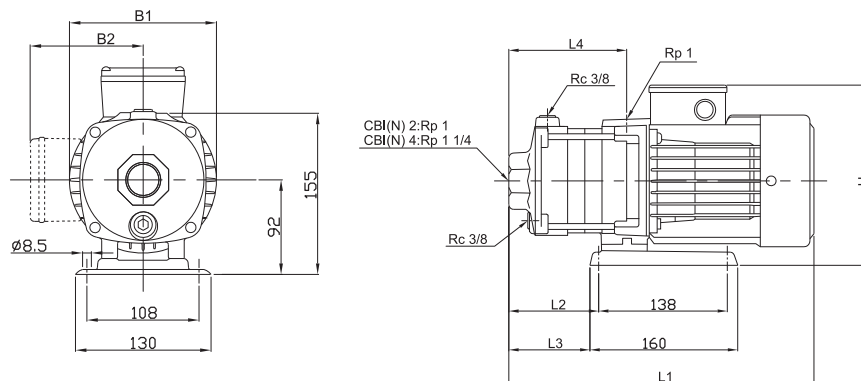

pump type	mm										Kg	
	L1	L2	L3	L4	B1	B2		H		1phase	3phase	
						1phase	3phase	1phase	3phase			
CBI 2-20	309	75	63	101	141	127	112	228	206	9.1	8.8	
CBI 2-30	327	93	81	119	141	127	112	228	206	10.0	9.6	
CBI 2-40	345	111	99	137	141	127	112	228	206	10.2	10.0	
CBI 2-50	403	129	117	155	141	127	112	228	206	11.8	11.5	
CBI 2-60	421	147	135	173	141	127	112	228	206	12.1	11.7	
CBI 4-20	318	84	72	110	141	127	112	228	206	9.8	9.5	
CBI 4-30	384	111	99	137	141	127	112	228	206	11.5	11.1	
CBI 4-40	412	138	126	164	141	127	112	228	206	12.8	12.6	

Performance curves 60Hz

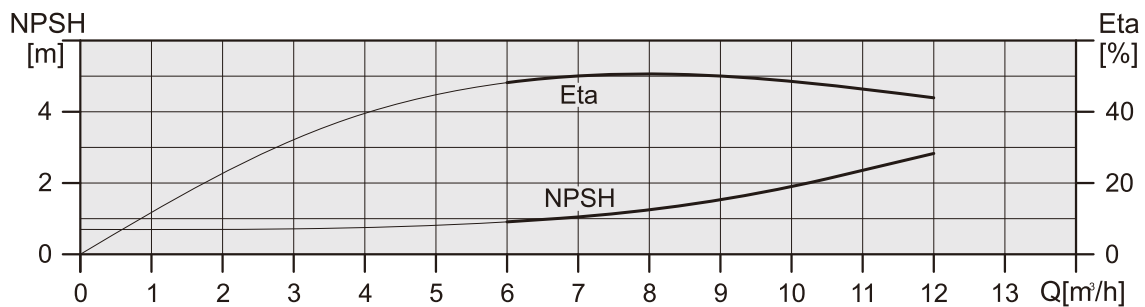
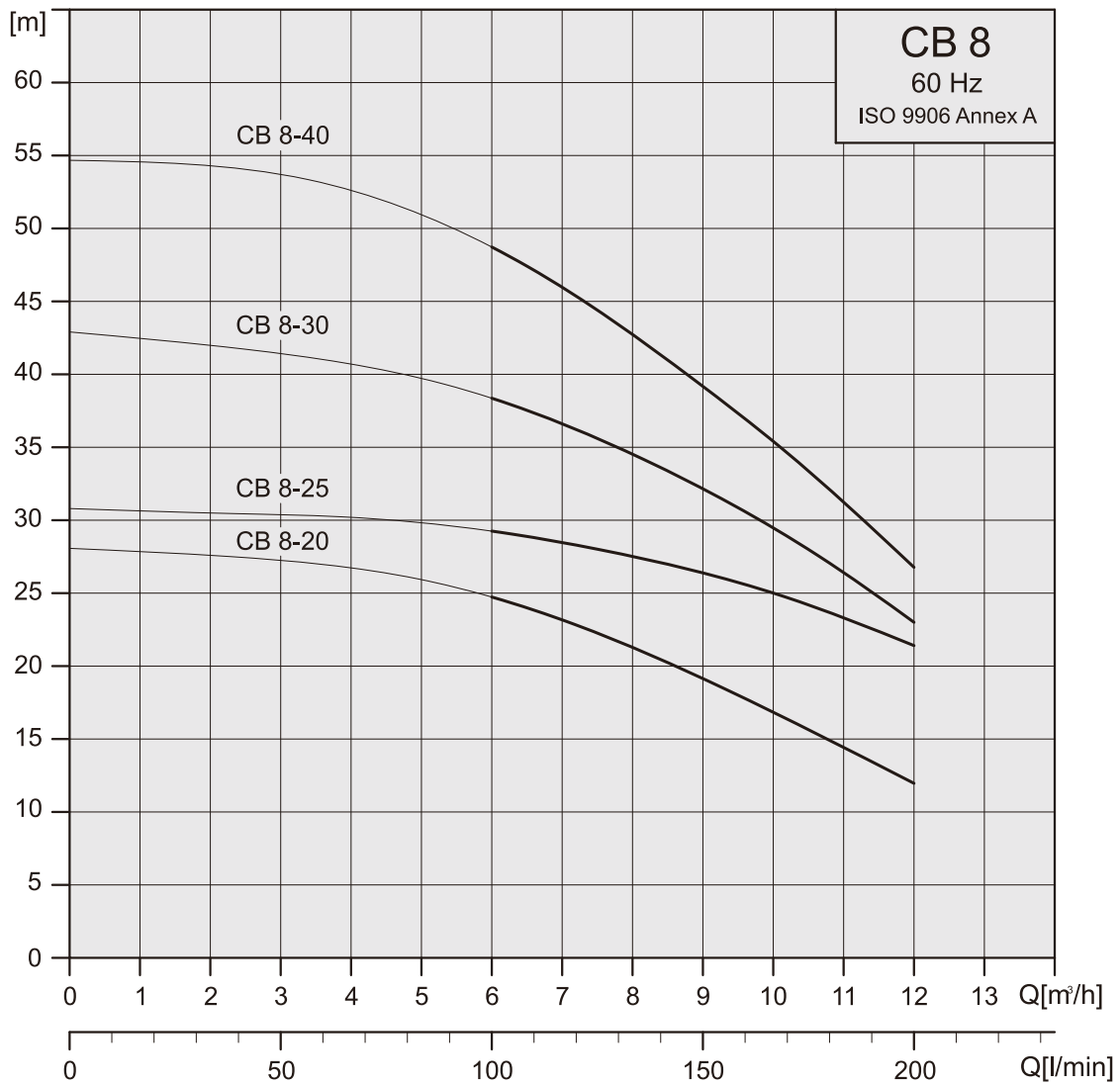

Electrical data, 3450 min⁻¹

pump type	1 x 110/220 V		3x220-255/380-440 V	
	P ₁ [W]	I _{1/1} [A]	P ₁ [W]	I _{1/1} [A]
CB 8-20	1250	11.7 / 5.9	1220	3.7-3.8 / 2.2-2.3
CB 8-25	-	-	1620	4.8-5.0 / 2.8-2.9
CB 8-30	1830	8.9(220V)	1860	5.7-5.5 / 3.3-3.2
CB 8-40	2080	10.4(220V)	3x220-277/380-480 V	
			2340	6.4-5.9 / 3.7-3.4

Performance curves 60Hz

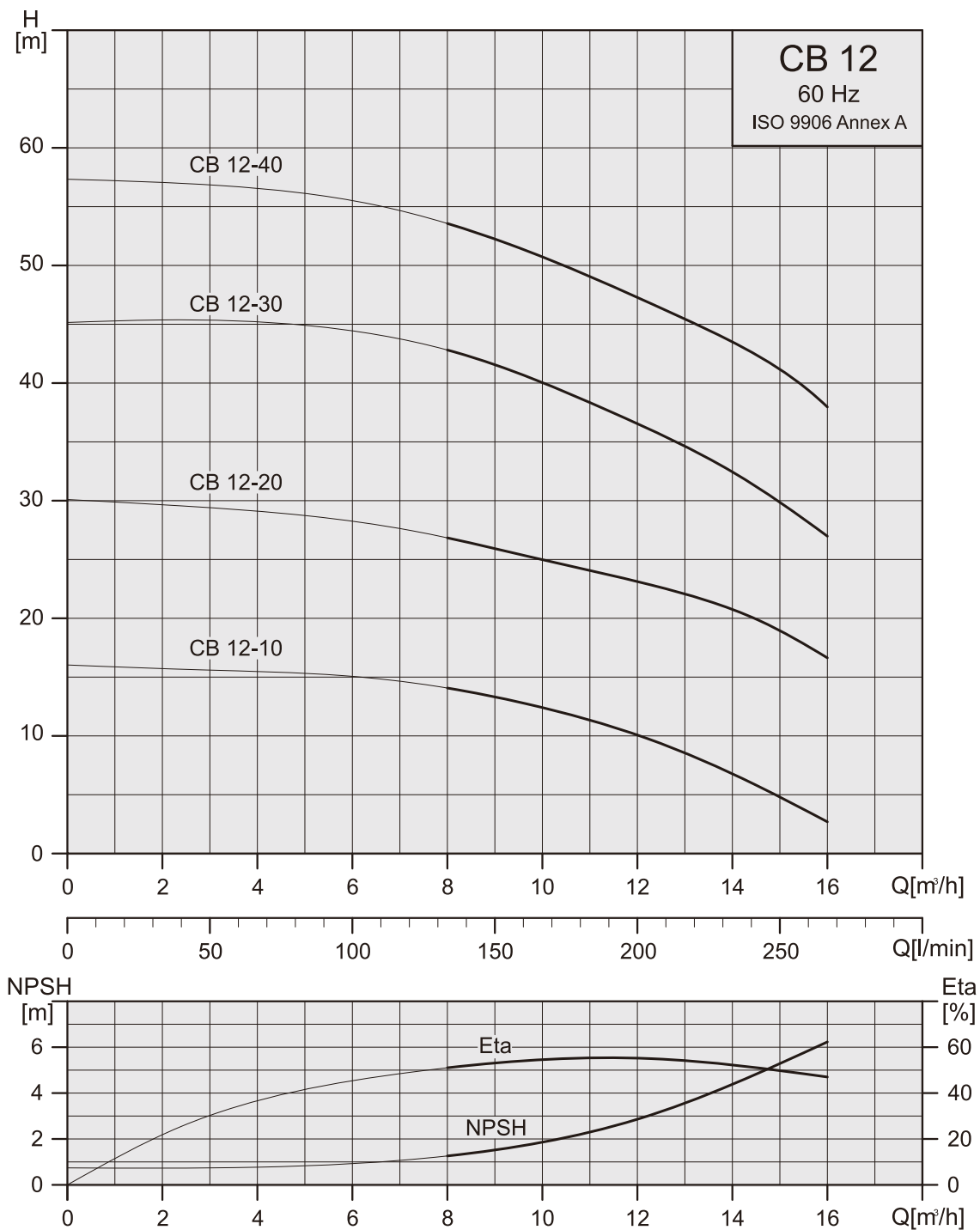

Electrical data, 3450 min⁻¹

pump type	1 x 110/220 V		3x220-255/380-440 V	
	P ₁ [W]	I _{1/n} [A]	P ₁ [W]	I _{1/n} [A]
CB 12-10	-	-	910	3.5-3.7 / 2.0-2.1
CB 12-20	2120	9.4(220V)	1960	6.0-5.9 / 3.5-3.4
CB 12-30	-	-	3x220-277/380-480 V	
			2940	8.8-10.2 / 5.1-5.9
CB 12-40	-	-	3810	11.2-11.3 / 6.5-6.6

Dimensions and Weights 60Hz

CB-8

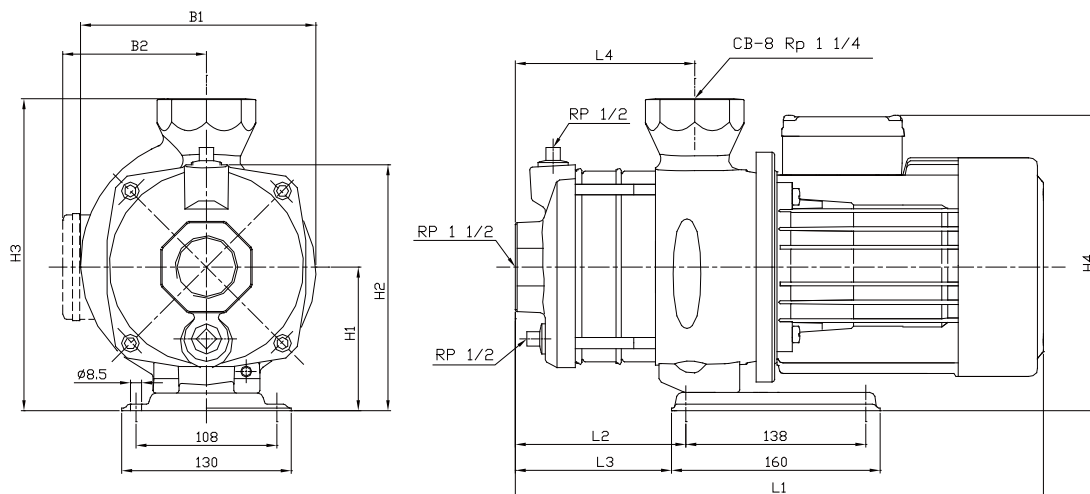

pump type	mm														Kg	
	L1		L2	L3	L4	B1		B2		H1	H2	H3	H4		1phase	3phase
	1phase	3phase				1phase	3phase	1phase	3phase				1phase	3phase		
CB 8-20	360	360	54	42	78	181	181	136	116	112	190	240	248	228	18.6	18.35
CB 8-25	-	390	84	72	108	-	181	-	116	112	190	240	-	228	-	20.25
CB 8-30	448	390	102	90	108	185	181	156	116	112	190	240	268	228	25.98	20.35
CB 8-40	448	448	102	90	108	185	185	156	141	112	190	240	268	253	26.2	26.15

CB-12

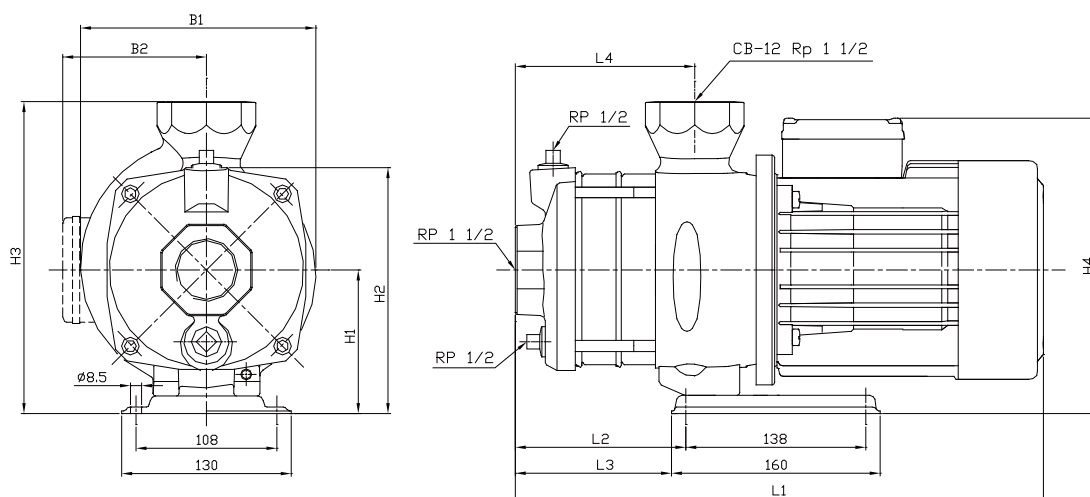

pump type	mm														Kg	
	L1		L2	L3	L4	B1		B2		H1	H2	H3	H4		1phase	3phase
	1phase	3phase				1phase	3phase	1phase	3phase				1phase	3phase		
CB 12-10	-	360	54	42	78	-	181	-	116	112	190	240	-	228	-	16.2
CB 12-20	419	360	54	42	78	185	181	156	116	112	190	240	268	228	25.24	19.1
CB 12-30	-	425	102	90	108	-	185	-	141	112	190	240	-	253	-	28.3
CB 12-40	-	471	102	90	108	-	196	-	147	125	203	253	-	272	-	33.64

Performance range, 50Hz

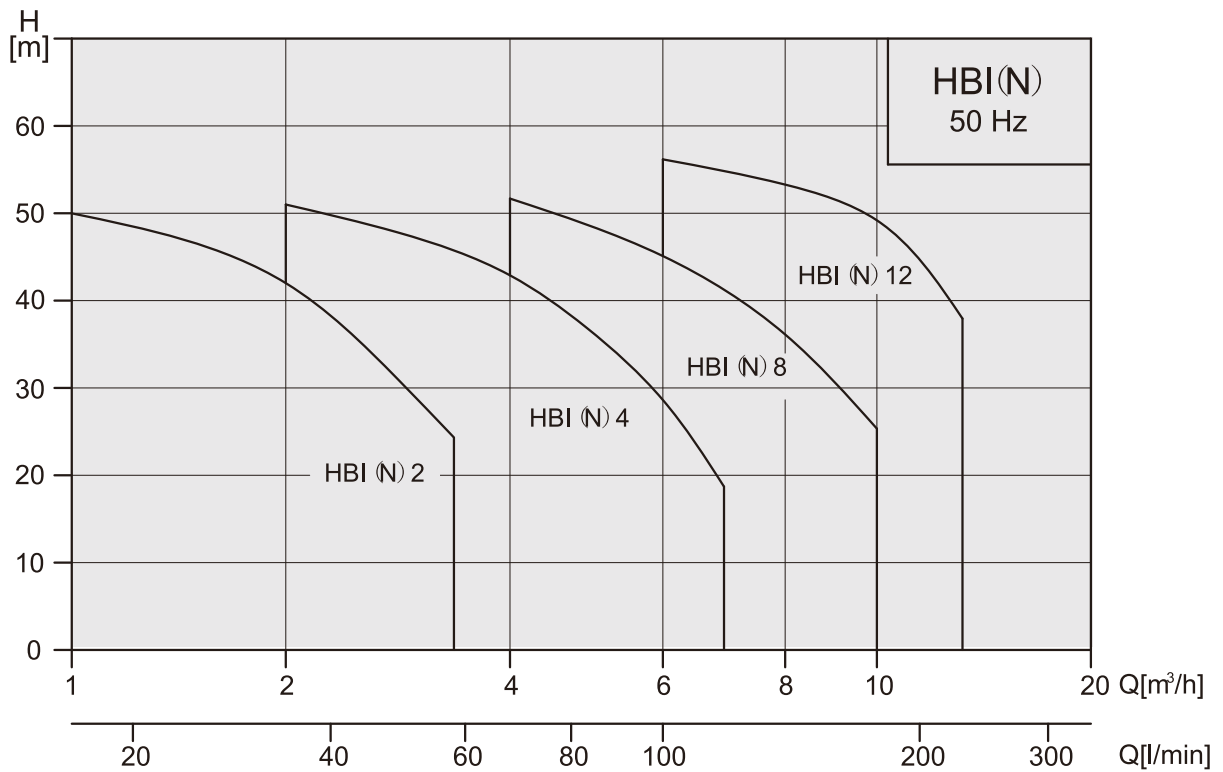

Performance range, 60Hz

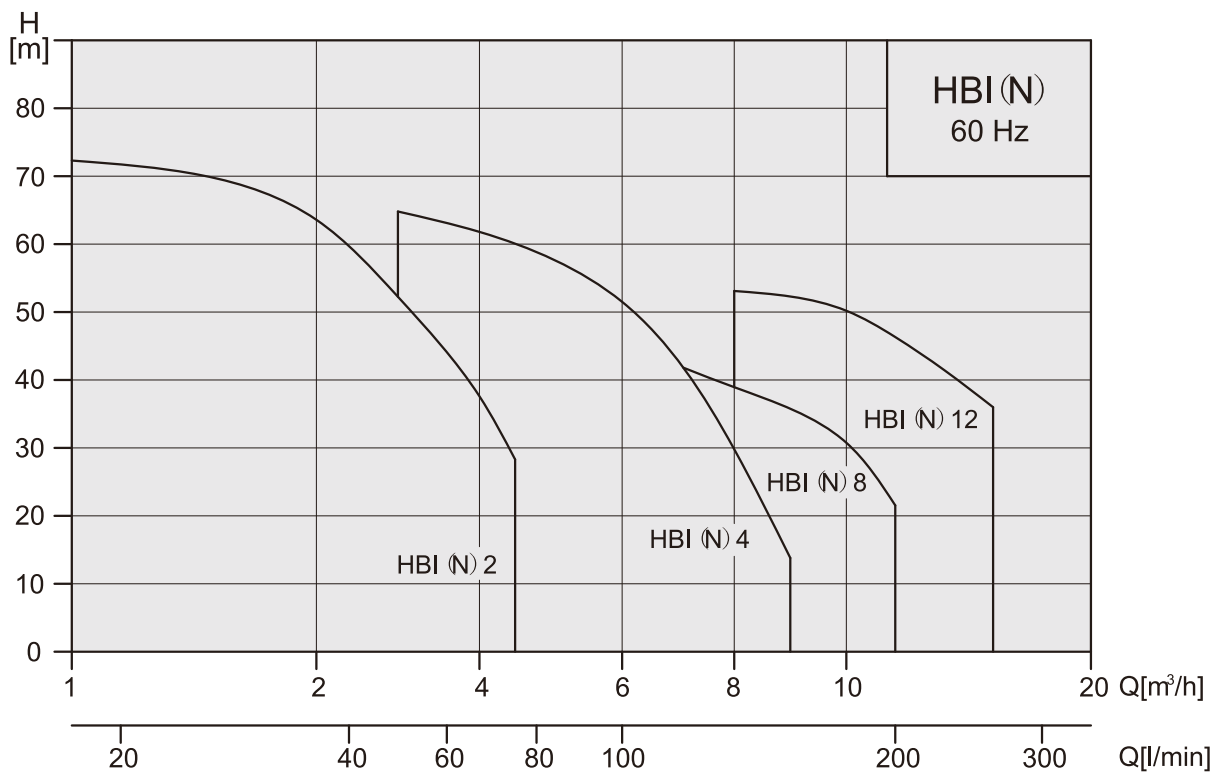

Applications

Water supply and pressure boosting
 Air-conditioning
 Water treatment
 Heating and cooling in industrial processes
 Industrial washing and dish-washing machines
 softened water
 Pressure boosting of process water
 Fertilizer/dosing systems



Pump

A horizontal, multistage centrifugal pump is made of stainless steel. The pump is a non-self priming type and fitted with a mechanical shaft seal.

Connection \ Pump	HBI(N) 2	HBI(N) 4	HBI(N) 8	HBI(N) 12
Suction port	Rp 1	Rp1 1/4	Rp1 1/2	Rp 1 1/2
Discharge port	Rp 1	Rp1 1/4	Rp1 1/2	Rp 1 1/2
Drain hole, priming hole	G 3/8	G 3/8	G 3/8	G 3/8

Motor

Totally enclosed and fan-cooled standard motor.

Standard voltages:	50HZ 1Ø		50HZ 3Ø	
	0. 5HP~3. 0HP	220~240V	0. 5HP~4. 0HP	220~240V/380~415V
Insulation class:F	60HZ 1Ø		60HZ 3Ø	
	0. 5HP~1. 0HP	110/220V	0. 5HP~1. 5HP	220~255V/380~440V
Enclosure class:IP54	0. 5HP~3. 0HP	220~240V	2. 0HP~4. 0HP	220~277V/380~480V

Operating conditions

Liquid temperature range: 0°C ~+110°C

Maximum ambient temperature: +40°C

Maximum operating pressure: 10 kg./cm².

Maximum inlet pressure is limited by maximum operating pressure.

Liquids to be pumped

These pumps are designed for pumping freely flowing non-corrosive, non-explosive, and non-flammable liquids. The liquids to be pumped must also be free of solid matter, sands, fibers, and similar materials.

Most common non-highly corrosive watery liquids, oily liquids, hot and cold liquids can be pumped with these pumps.

The suitability of these pumps for pumping any particular liquid depends upon a number of factors, such as the ph value, contents of chemicals such as chlorides, oils, the temperature of the liquids, etc..

Please contact your distributor or the factory if there are any questions as to whether certain liquids are suitable for pumping with these pumps.

Type key

Example: HBI	4	-	30	-	HQBE
HBN	4	-	30	-	HQQE
Type	Nominal flow rate (m ³ /h)		Number of stages x 10		Mechanical Seals

Mechanical seals

List of Materials		Mechanical Seals	HBI 2/4	HBI 8/12	HBN 2/4	HBN 8/12
Q : Silicon carbide	E : EPDM	HQB	●	●	Optional	Optional
B : Carbon	V : Viton	HQQ	Optional	Optional	●	●
H : Seal Type		O-rings				
		E	●	●	●	●
		V	●	●	●	●

● Standard

Material construction

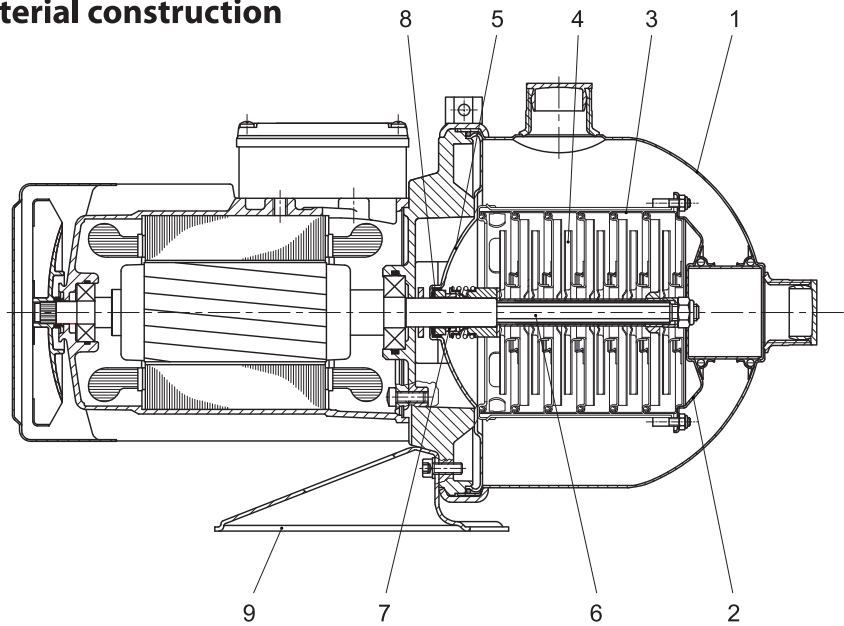

Materials

Pos.	Description	Materials	
		HBI	HBN
1	Pump casing	SS304	SS316
2	Suction inter-connector	SS304	SS316
3	Chamber	SS304	SS316
4	Impeller	SS304	SS316
5	Cover plate	SS304	SS316
6	Shaft	SS431	SS316
7	Mechanical seal	Silicon carbide/Carbon	Silicon carbide/S i c
8	O-ring	EPDM or Viton	EPDM or Viton
9	Base plate	Steel	Steel

Performance curves 50 Hz

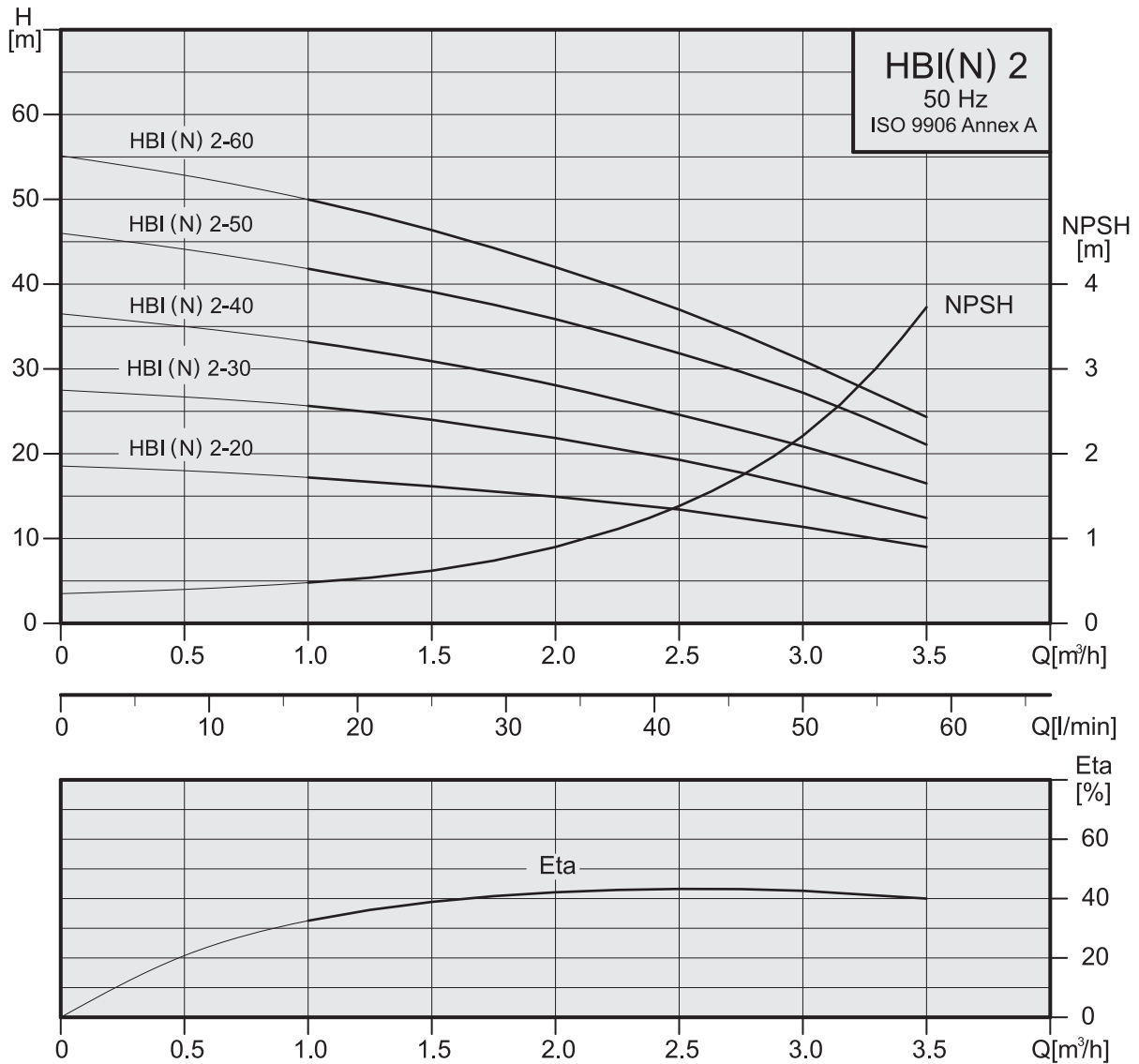

Electrical data, 2850 min⁻¹

pump type	1 x 220-240 V		3 x 220-240 Δ/380-415 Y V	
	P _i [W]	I _{1/n} [A]	P _i [W]	I _{1/n} [A]
HBI/HBN 2-20	360	1.7-1.9	370	2.0-2.7 / 1.2-1.6
HBI/HBN 2-30	470	2.3-2.2	550	2.4-2.8 / 1.4-1.6
HBI/HBN 2-40	580	2.7-2.6	650	2.4-2.7 / 1.4-1.6
HBI/HBN 2-50	720	3.2-3.3	810	2.7-3.0 / 1.6-1.8
HBI/HBN 2-60	830	3.8-3.6	910	2.9-3.3 / 1.7-1.9

Performance curves 50 Hz

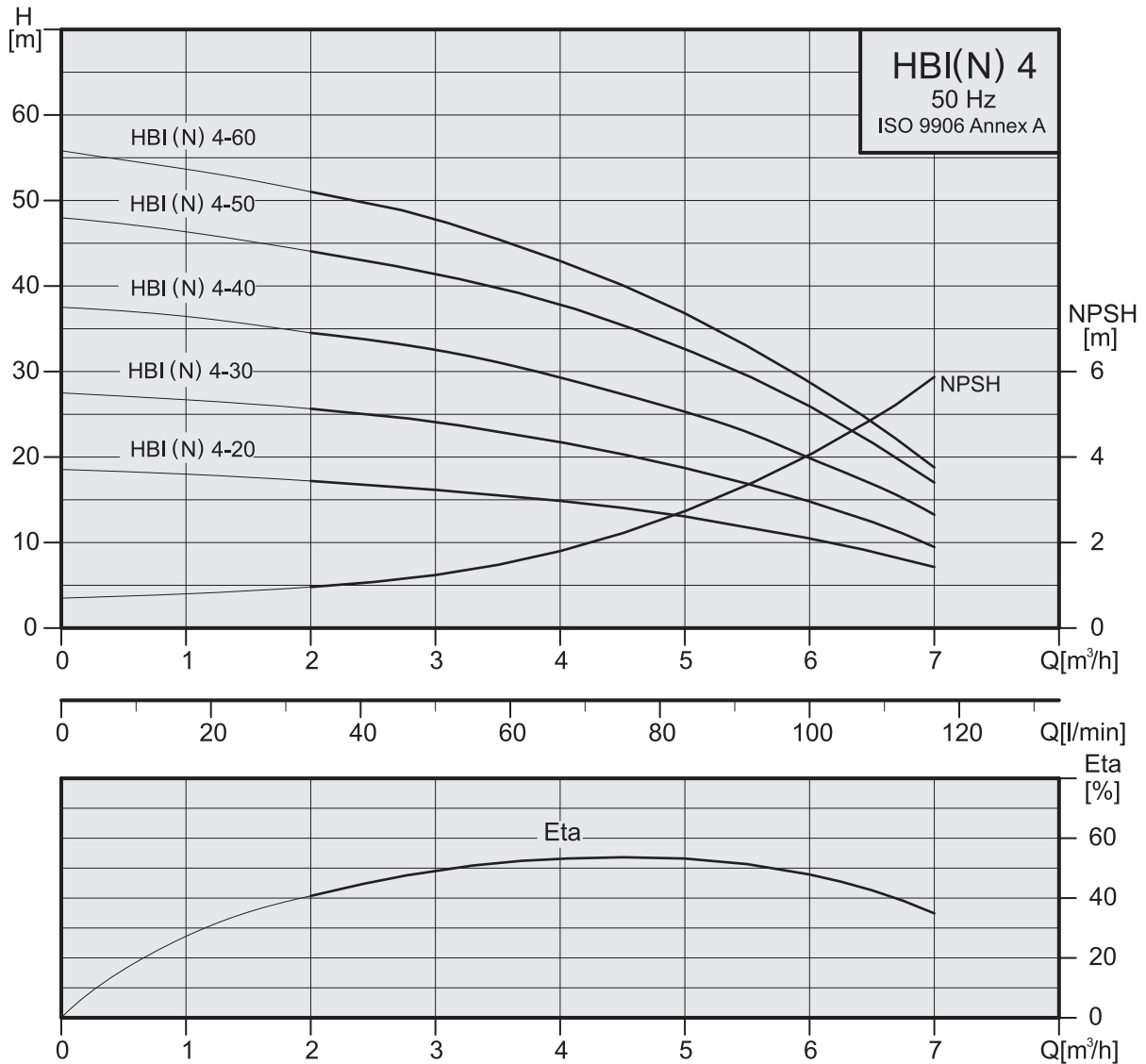

Electrical data, 2850 min⁻¹

pump type	1 x 220-240 V		3 x 220-240 Δ/380-415 Y V	
	P ₁ [W]	I _{1/n} [A]	P ₁ [W]	I _{1/n} [A]
HBI/HBN 4-20	580	2.7-2.6	660	2.5-2.9 / 1.5-1.7
HBI/HBN 4-30	820	3.9-3.7	850	2.8-3.0 / 1.6-1.7
HBI/HBN 4-40	1000	4.6-4.4	1060	3.3-3.5 / 1.9-2.0
HBI/HBN 4-50	1240	5.8-5.5	1310	4.2-4.5 / 2.4-2.6
HBI/HBN 4-60	1510	7.1-6.9	1550	5.2-5.6 / 3.0-3.3

Dimensions and weights 50 Hz

HBI(N)-2

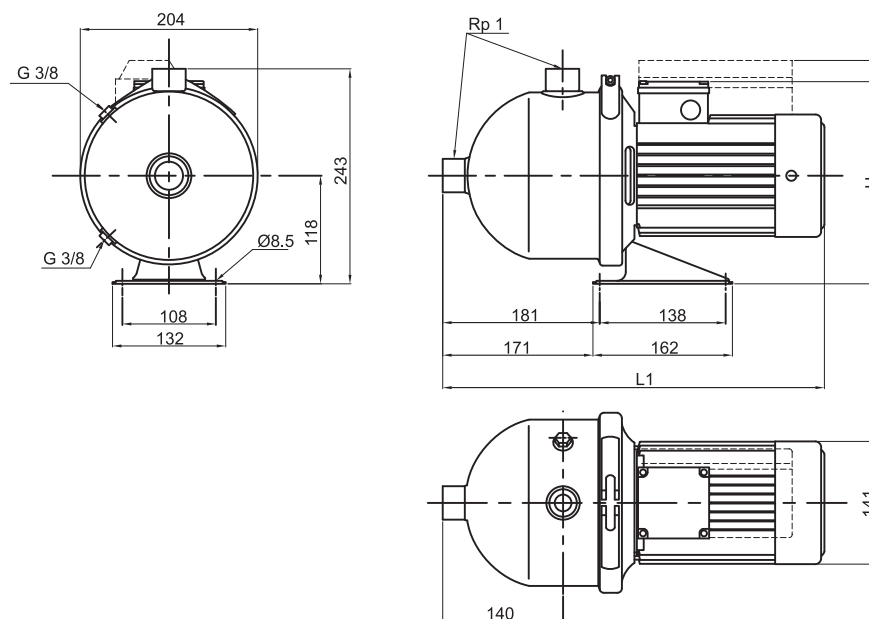

HBI(N)-4

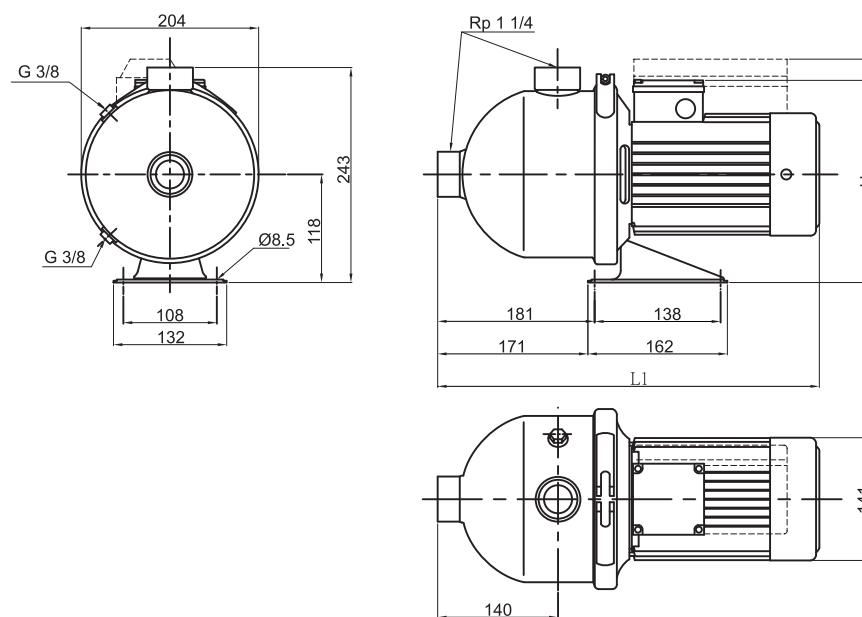

pump type	Dimension (mm)				Net Weight (kg)
	1-Phase		3-Phase		
	L1	H	L1	H	
HBI/HBN 2-20	403	255	403	233	9.6
HBI/HBN 2-30	403	255	403	233	9.9
HBI/HBN 2-40	403	255	403	233	10.1
HBI/HBN 2-50	403	255	403	233	10.8
HBI/HBN 2-60	403	255	403	233	11.0
HBI/HBN 4-20	403	255	403	233	9.6
HBI/HBN 4-30	403	255	403	233	9.9
HBI/HBN 4-40	403	255	403	233	10.6
HBI/HBN 4-50	441	255	441	233	12.1
HBI/HBN 4-60	441	255	441	233	12.3

Performance curves 50Hz

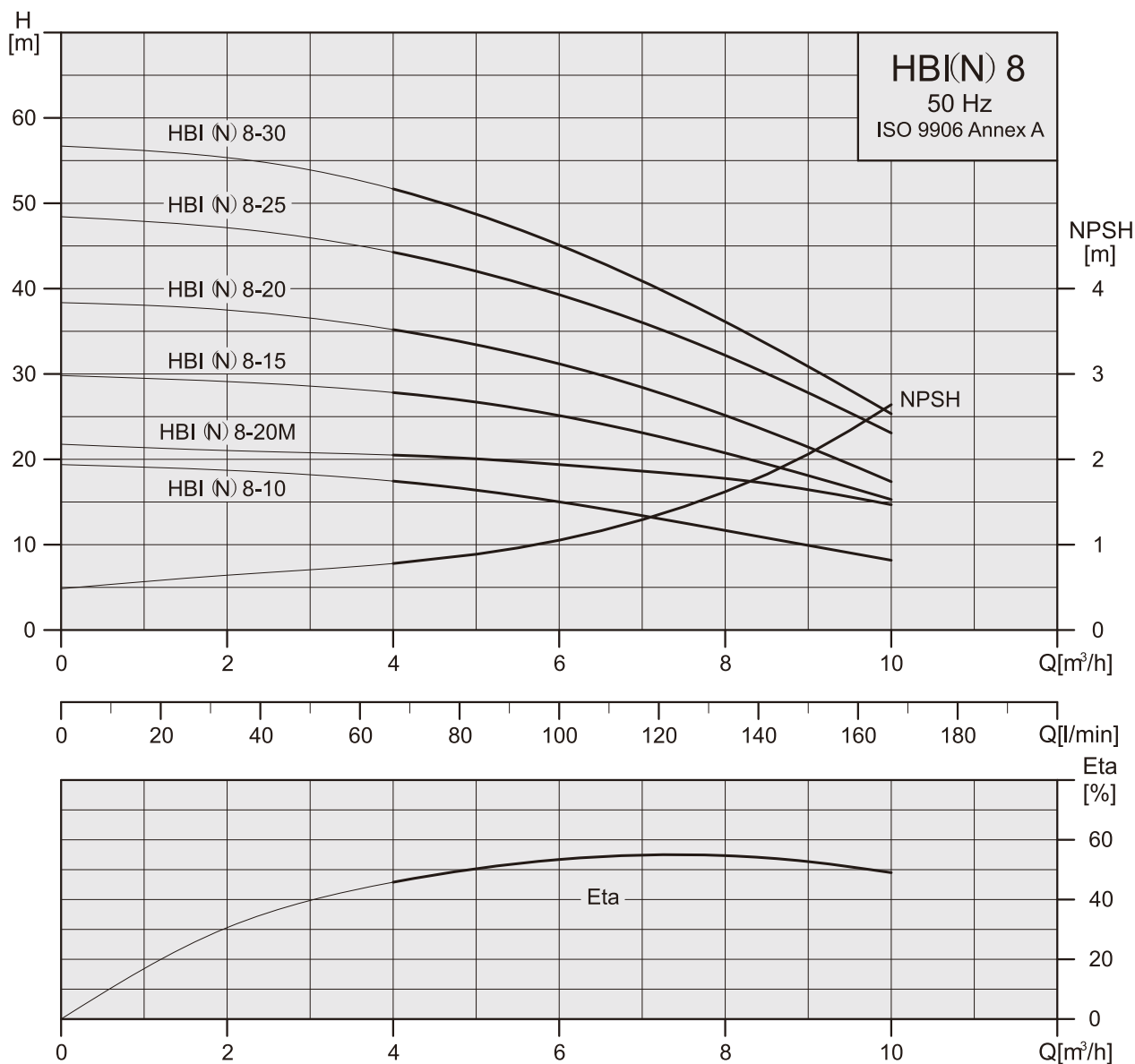

Electrical data, 2850 min⁻¹

pump type	1x220-240 V		3x220-240/380-415 V	
	P ₁ [W]	I _{1/1} [A]	P ₁ [W]	I _{1/1} [A]
HBI/HBN 8-10	760	3.3-3.1	810	2.7-3.1 / 1.6-1.8
HBI/HBN 8-20M	-	-	1120	4.2-4.5 / 2.4-2.6
HBI/HBN 8-15	1150	5.3-5.1	1190	3.9-4.4 / 2.3-2.6
HBI/HBN 8-20	1420	6.8-6.6	1450	5.0-5.5 / 2.9-3.2
HBI/HBN 8-25	1880	8.1-7.9	1840	5.8-6.5 / 3.4-3.8
HBI/HBN 8-30	2100	9.1-9.0	2050	6.4-6.9 / 3.7-4.0

Performance curves 50Hz

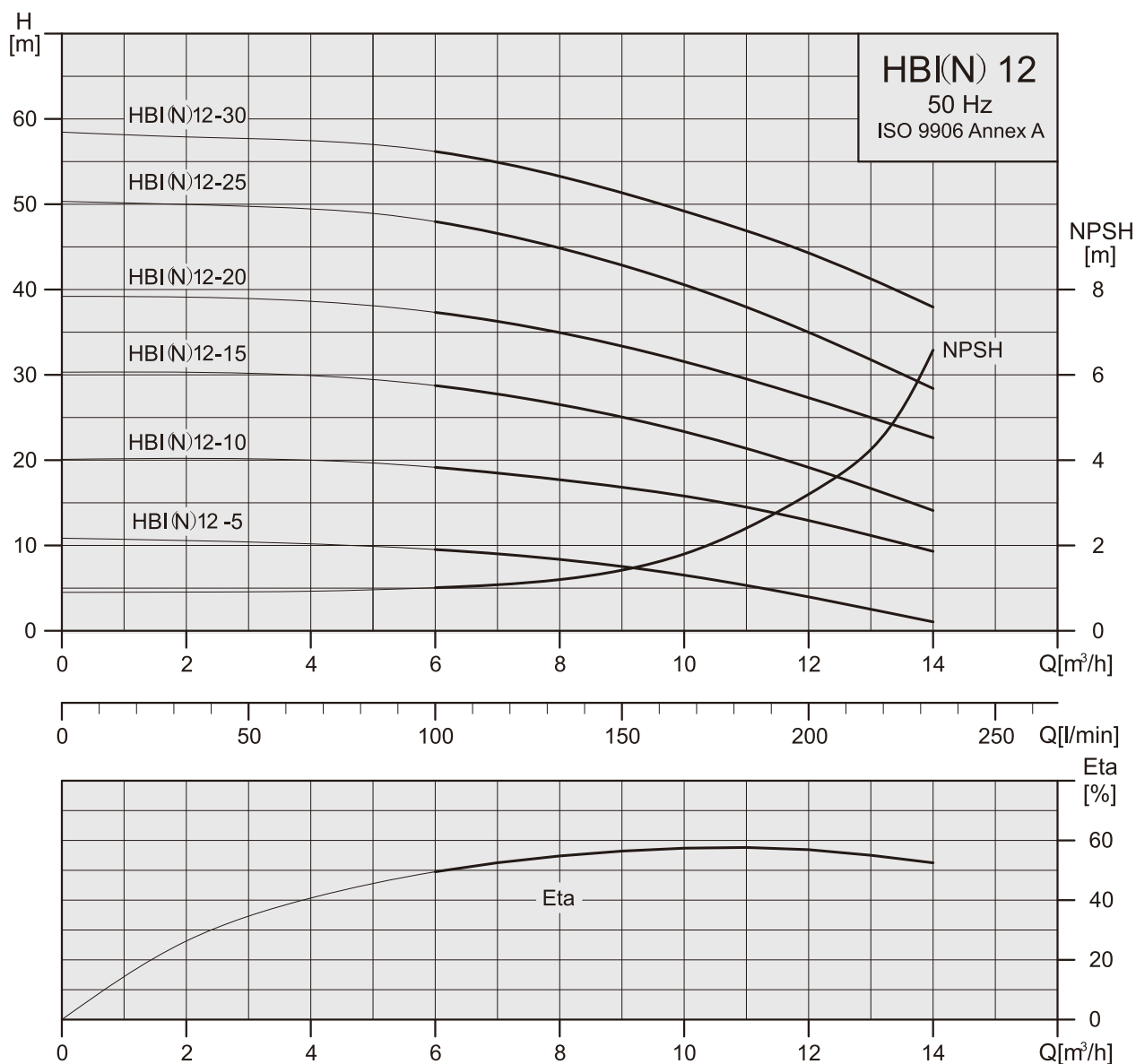

Electrical data, 2850min⁻¹

pump type	1x220-240 V		3x220-240/380-415 V	
	P ₁ [W]	I _{1/1} [A]	P ₁ [W]	I _{1/1} [A]
HBI/HBN 12-05	-	-	550	2.4-2.8 / 1.4-1.6
HBI/HBN 12-10	1170	5.3-5.1	1190	3.6-3.8 / 2.1-2.2
HBI/HBN 12-15	1650	7.6-7.5	1690	5.5-6.0 / 3.2-3.5
HBI/HBN 12-20	2310	10.6-10.4	2350	7.0-7.4 / 4.0-4.3
HBI/HBN 12-25	2980	13.1-12.7	2880	9.0-9.3 / 5.2-5.4
HBI/HBN 12-30	-	-	3610	11.7-12.1 / 6.8-7.0

Dimensions and weights 50Hz

HBI(N)-8

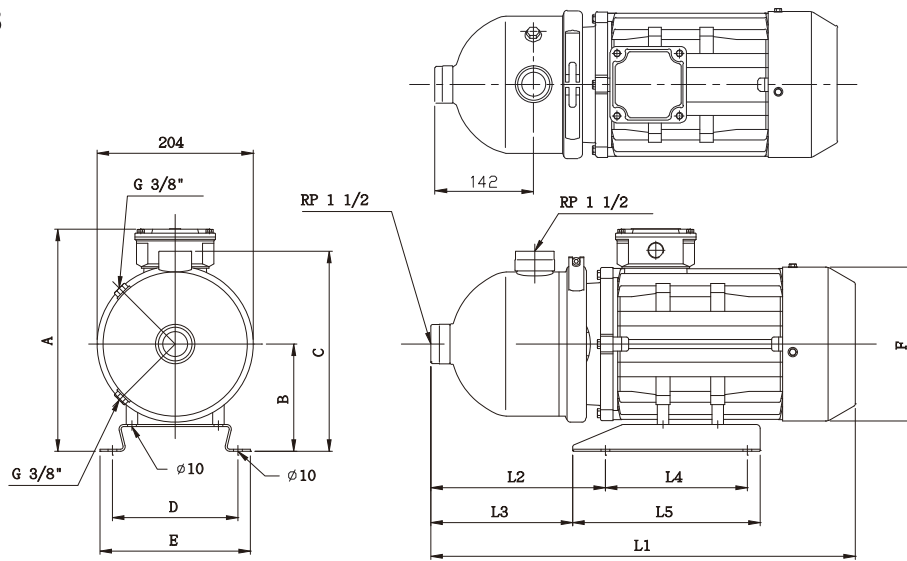

HBI(N)-12

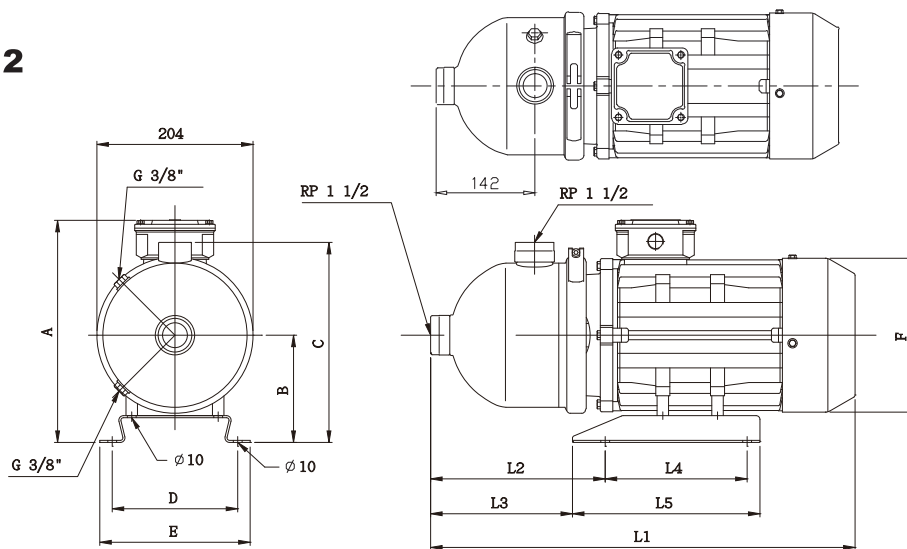

pump type	motor		Dimension[mm]														
	P ₂		L1		L2	L3	L4	L5	A		B	C	D	E	F	Net Weight(kg)	
	phase	HP	1phase	3phase					1phase	3phase						1phase	3phase
HBI(N) 8-10	1/3	0.75	403	403	181	171	138	162	255	233	118	243	108	132	141	10.20	10.02
HBI(N) 8-15	1/3	1.0	441	441	181	171	138	162	255	233	118	243	108	132	141	12.28	12.08
HBI(N) 8-20M	3	1.0	-	441	181	171	138	162	-	233	118	243	108	132	141	-	11.98
HBI(N) 8-20	1/3	1.5	441	441	181	171	138	162	255	233	118	243	108	132	141	13.54	13.34
HBI(N) 8-25	1	2.0	514	-	200	180	195	235	267	-	121	245	158	178	177	23.08	-
	3	1.5	-	441	181	171	138	162	-	233	118	243	108	132	141	-	13.92
HBI(N) 8-30	1/3	2.0	514	514	200	180	195	235	267	261	121	245	158	178	177	23.14	22.22
HBI(N) 12-05	3	0.5	-	403	181	171	138	162	-	233	118	243	108	132	141	-	9.41
HBI(N) 12-10	1/3	1.0	441	441	181	171	138	162	255	233	118	243	108	132	141	11.72	11.52
HBI(N) 12-15	1/3	1.5	441	441	181	171	138	162	255	233	118	243	108	132	141	13.38	13.18
HBI(N) 12-20	1/3	2.0	514	514	200	180	195	235	267	261	121	245	158	178	177	22.52	21.48
HBI(N) 12-25	1/3	3.0	514	514	200	180	195	235	267	261	121	245	158	178	177	25.74	24.36
HBI(N) 12-30	3	4.0	-	539	230	198	195	245	-	284	133	259	174	198	197	-	30.20

Performance curves 60 Hz

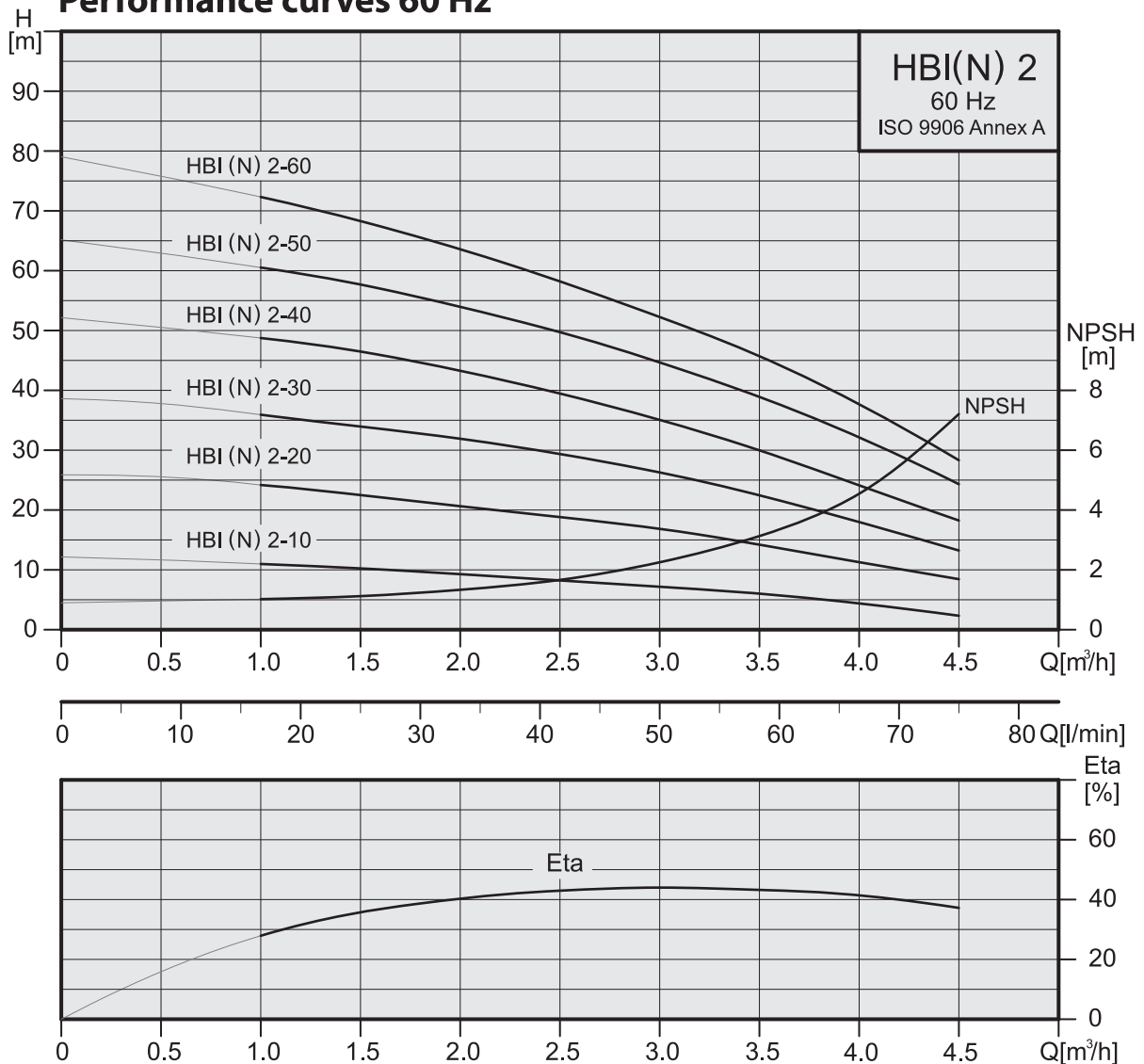

Electrical data, 3450 min⁻¹

pump type	1x110/220 V		3x220-255/380-440 V	
	P ₁ [W]	I _{1/1} [A]	P ₁ [W]	I _{1/1} [A]
HBI/HBN 2-10	390	5.9/3.0	360	1.5-1.6 / 0.9-1.0
HBI/HBN 2-20	570	6.6/3.4	540	1.7-1.8 / 1.0-1.1
HBI/HBN 2-30	750	7.6/3.8	720	2.2-2.3 / 1.3-1.4
HBI/HBN 2-40	980	9.3/4.7	950	3.0-3.2 / 1.75-1.9
HBI/HBN 2-50	1160	10.7/5.4	1170	3.8-3.9 / 2.2-2.3
HBI/HBN 2-60	1375	12.4/6.3	1330	4.1-4.2 / 2.35-2.45

Performance curves 60 Hz

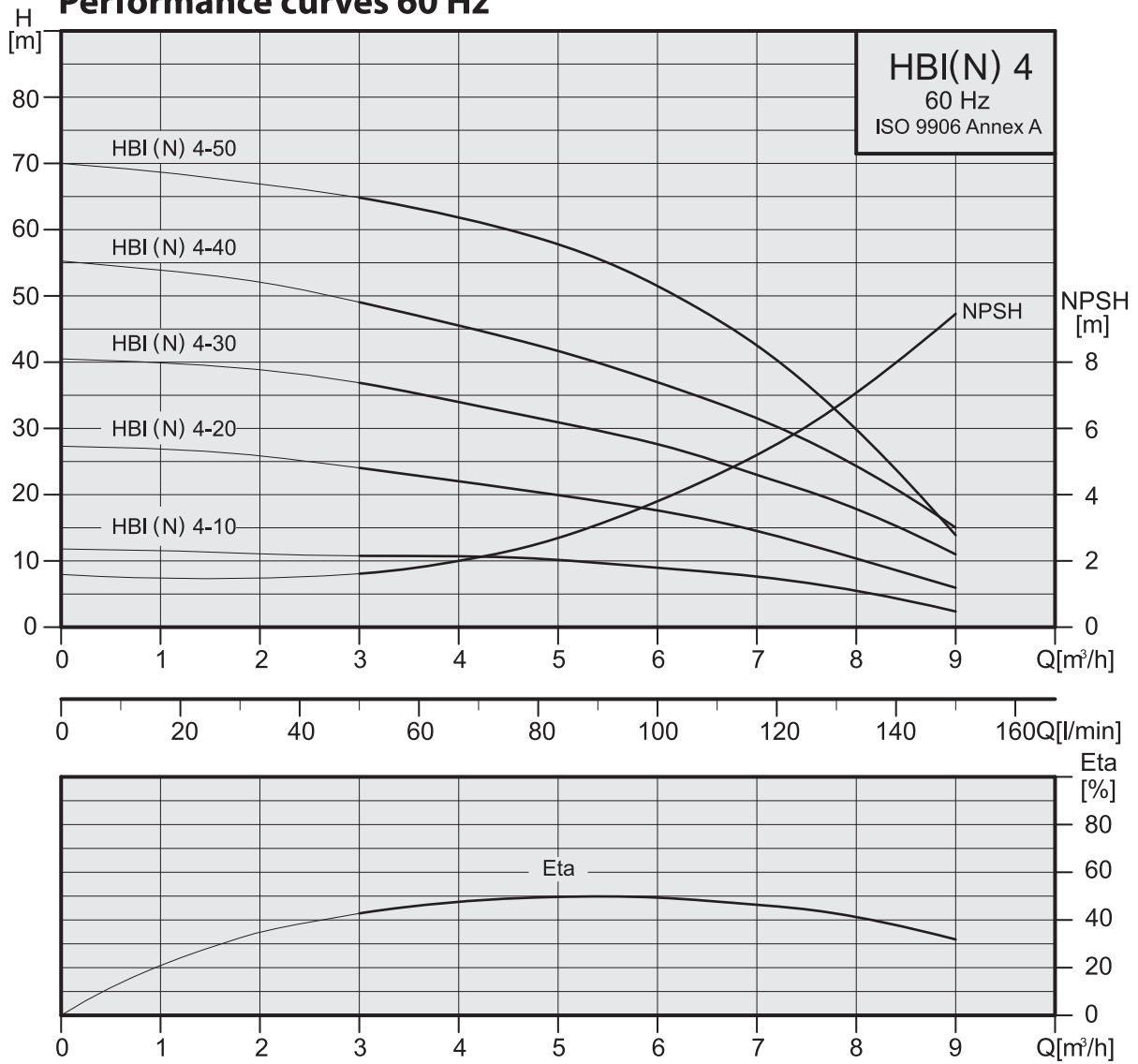

Electrical data, 3450 min^{-1}

pump type	1x110/220 V		3x220-255/380-440 V	
	P_i [W]	$I_{l/n}$ [A]	P_i [W]	$I_{l/n}$ [A]
HBI/HBN 4-10	530	5.9 / 3.1	560	1.8-1.9 / 1.1-1.2
HBI/HBN 4-20	970	9.3 / 4.7	910	2.9-3.1 / 1.7-1.8
HBI/HBN 4-30	1360	12.5 / 6.5	1280	4.1-4.2 / 2.4-2.5
HBI/HBN 4-40	1730	8.5(220V)	1675	4.7-4.8 / 2.7-2.8
HBI/HBN 4-50	2080	9.9(220V)	1995	5.7-6.0 / 3.3-3.5

Dimensions and weights 60 Hz

HBI(N)-2

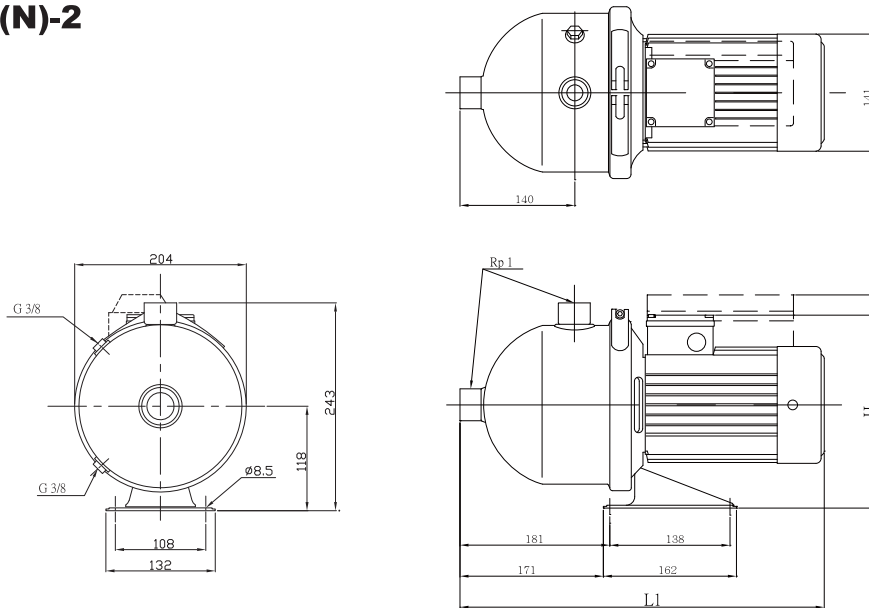

HBI(N)-4

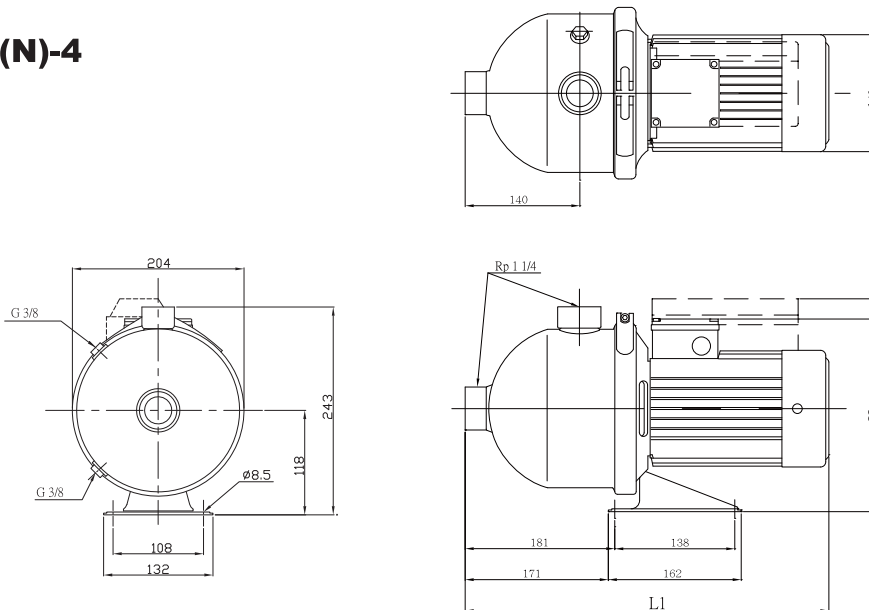

pump type	Dimension (mm)				Net Weight (kg)
	1-Phase		3-Phase		
	L1	H	L1	H	
HBI/HBN 2-10	403	255	403	233	9.5
HBI/HBN 2-20	403	255	403	233	9.5
HBI/HBN 2-30	403	255	403	233	9.8
HBI/HBN 2-40	403	255	403	233	10.3
HBI/HBN 2-50	441	255	441	233	11.7
HBI/HBN 2-60	441	255	441	233	12.0
HBI/HBN 4-10	403	255	403	233	9.5
HBI/HBN 4-20	403	255	403	233	9.5
HBI/HBN 4-30	403	255	403	233	10.1
HBI/HBN 4-40	441	255	441	233	11.5
HBI/HBN 4-50	441	255	441	233	12.8

Performance curves 60Hz

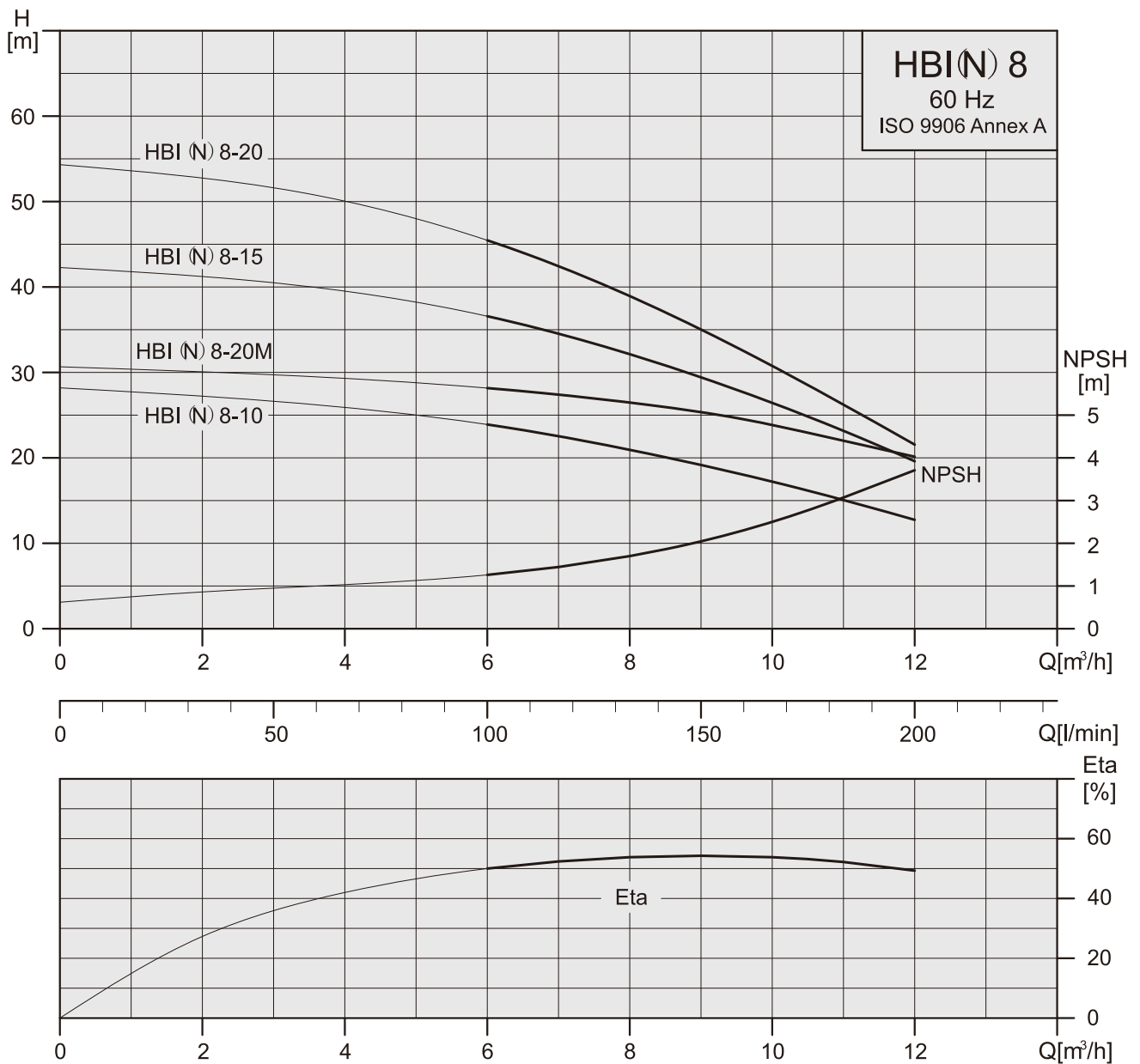

Electrical data, 3450 min⁻¹

pump type	1x110/220 V		3x220-255/380-440 V	
	P ₁ [W]	I _{1/n} [A]	P ₁ [W]	I _{1/n} [A]
HBI/HBN 8-10	1280	11.4 / 6.0	1210	3.9-4.1 / 2.3-2.4
HBI/HBN 8-20M	1730	8.3(220V)	1670	5.2-5.3 / 3.0-3.1
HBI/HBN 8-15	2080	9.3(220V)	1890	5.6-5.7 / 3.2-3.3
HBI/HBN 8-20	2460	10.9(220V)	3x220-277/380-480 V	
			2360	7.1-6.9 / 4.1-4.0

Performance curves 60Hz

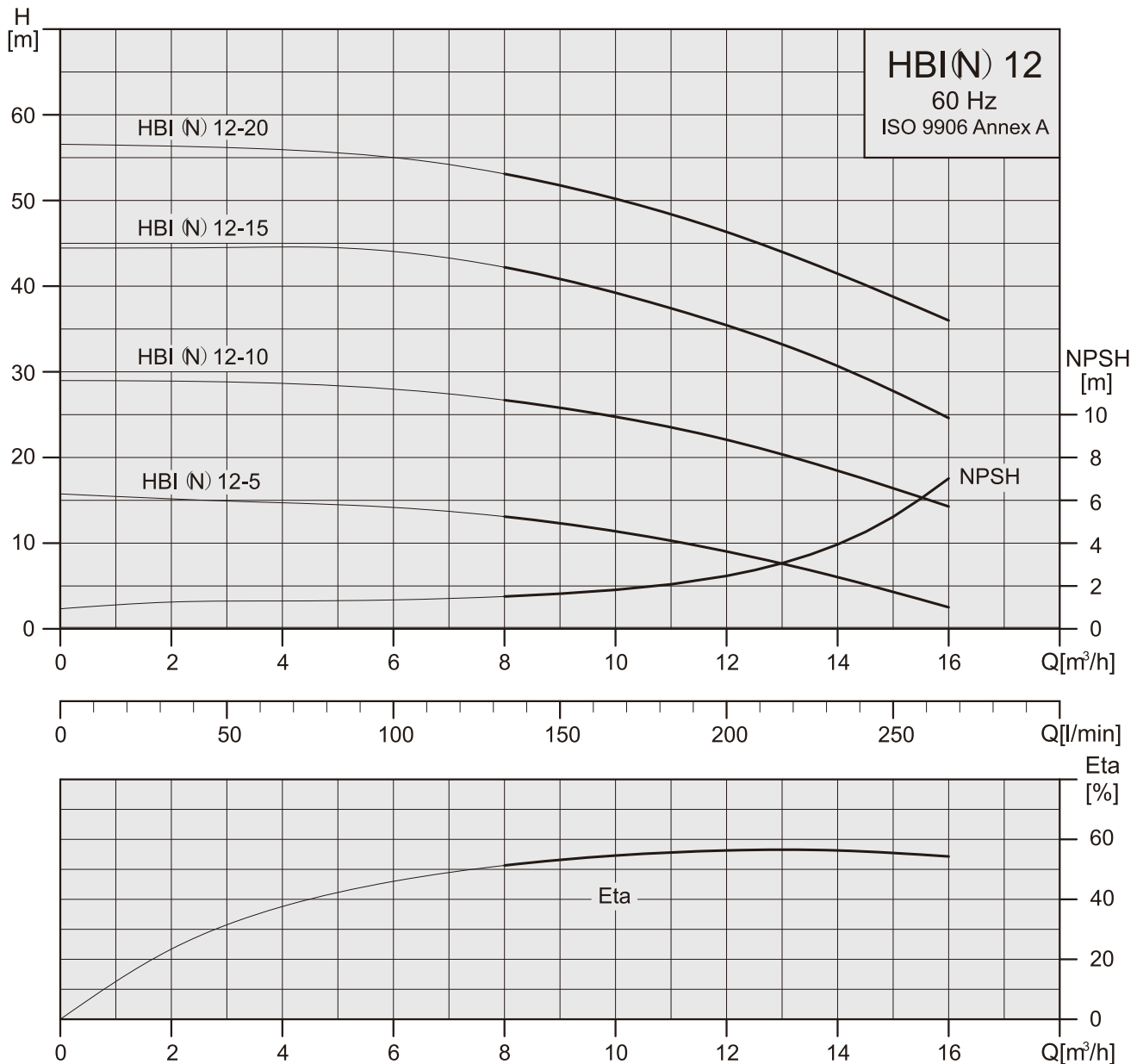

Electrical data, 3450 min⁻¹

pump type	1x110/220 V		3x220-255/380-440 V	
	P ₁ [W]	I _{1/n} [A]	P ₁ [W]	I _{1/n} [A]
HBI/HBN 12-05	940	8.5 / 4.5	850	2.8-3.0 / 1.6-1.75
HBI/HBN 12-10	2170	9.7(220V)	1930	5.7-5.9 / 3.3-3.4
HBI/HBN 12-15	-	-	3x220-277/380-480 V	
			2860	9.2-8.9 / 5.3-5.1
HBI/HBN 12-20	-	-	3950	11.2-11.8 / 6.5-6.8

Dimensions and weights 60 Hz

HBI(N)-8

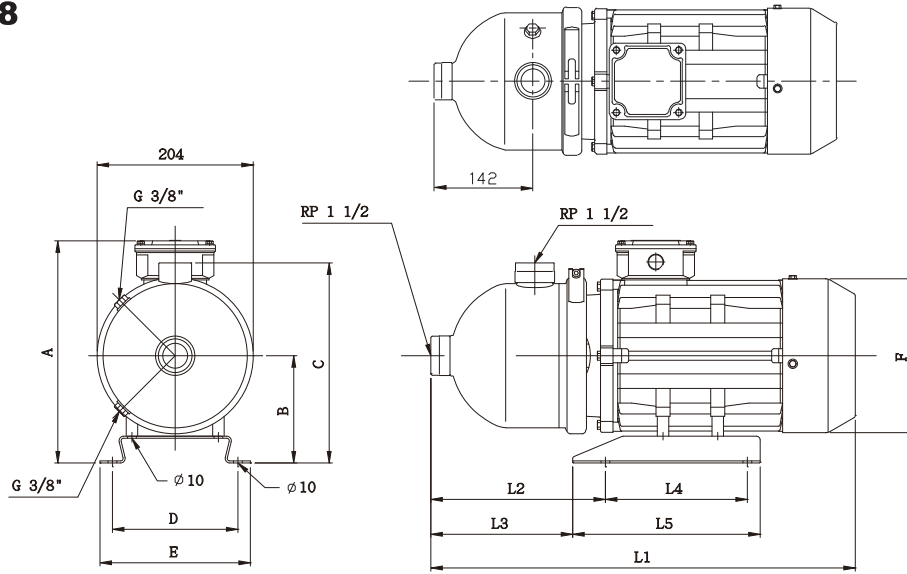

HBI(N)-12

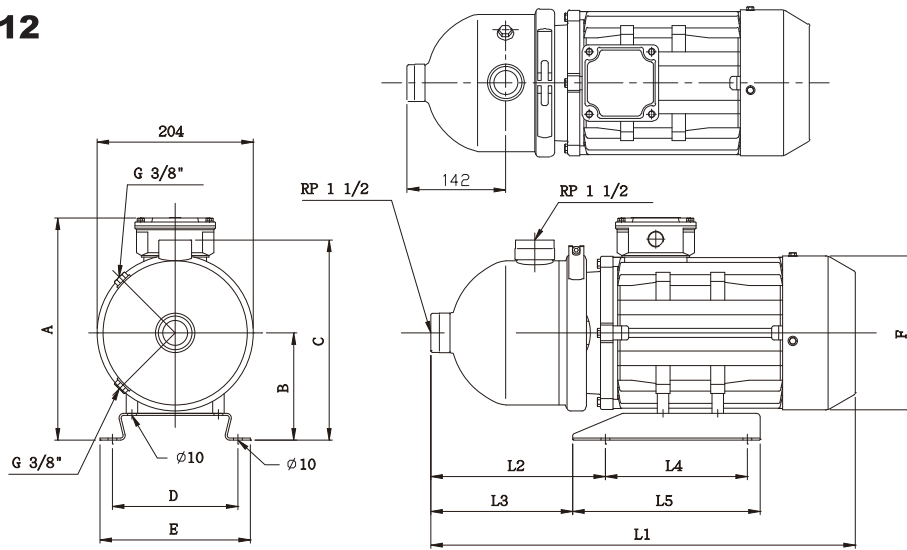

pump type	motor		Dimension[mm]														Net Weight(kg)	
	P ₂		L1		L2	L3	L4	L5	A		B	C	D	E	F	1phase	3phase	
	phase	HP	1phase	3phase					1phase	3phase								
HBI(N) 8-10	1/3	1.0	441	441	181	171	138	162	255	233	118	243	108	132	141	11.70	11.50	
HBI(N) 8-15	1	2.0	514	-	200	180	195	235	267	-	121	245	158	178	177	21.42	-	
	3	1.5	-	441	181	171	138	162	-	233	118	243	108	132	141	-	13.18	
HBI(N) 8-20M	1/3	1.5	441	441	181	171	138	162	255	233	118	243	108	132	141	13.24	13.05	
HBI(N) 8-20	1	2.0	514	514	200	180	195	235	267	261	121	245	158	178	177	21.50	21.60	
	3	1.5	-	441	181	171	138	162	-	233	118	243	108	132	141	-	12.64	
HBI(N) 12-05	1/3	0.75	403	403	181	171	138	162	255	233	118	243	108	132	141	10.26	10.06	
HBI(N) 12-10	1	2.0	514	-	200	180	195	235	267	-	121	245	158	178	177	20.64	-	
	3	1.5	-	441	181	171	138	162	-	233	118	243	108	132	141	-	12.64	
HBI(N) 12-15	3	3.0	-	493	200	180	195	235	-	261	121	245	158	178	177	-	23.72	
HBI(N) 12-20	3	4.0	-	514	230	198	195	245	-	284	133	259	174	198	197	-	29.40	

SISTEMA[®]